



# FUJII ELECTRIC

## SPLIT TYPE AIR CONDITIONER (50Hz)

## DUCT type

# SERVICE MANUAL

Models	Indoor unit	Outdoor unit
	RD-90EA	RO-90EPA
	RD-90TA	RO-90TPA



### CONTENTS

SPECIFICATIONS .....	1
OUTLINE AND DIMENSIONS .....	2
CIRCUIT DIAGRAM .....	5
INDOOR P. C. BOARD CIRCUIT DIAGRAM .....	8
INDOOR P. C. BOARD LAYOUTS .....	10
OUTDOOR P. C. BOARD CIRCUIT DIAGRAM .....	12
OUTDOOR P. C. BOARD LAYOUTS .....	14
REFRIGERANT SYSTEM DIAGRAM .....	15
DISASSEMBLY ILLUSTRATION .....	16
PARTS LIST .....	23



Большая библиотека технической документации

<https://splitsystema48.ru/instrukcii-po-ekspluatacii-kondicionerov.html>

каталоги, инструкции, сервисные мануалы, схемы.

# S P E C I F I C A T I O N S

INDOOR UNIT		RD-90EA	RD-90TA
OUTDOOR UNIT		RO-90EPA	RO-90TPA
COOLING CAPACITY	(kW)	24.8 - 25.4	24.8 - 25.4
HEATING CAPACITY	(kW)	—	28.9 - 29.5

## ELECTRICAL DATA

POWER SOURCE	(V)	380 - 415	
FREQUENCY	(Hz)	50	
RUNNING CURRENT	(A)	COOLING	19.5 - 19.5
		HEATING	—
INPUT WATTS	(kW)	COOLING	12.2 - 12.5
		HEATING	—
EER	(kW/kW)	COOLING	2.03 - 2.03
		HEATING	—
MOISTURE REMOVAL	(ℓ/hr)	7.5	
AIR CIRCULATION-Hi	(m <sup>3</sup> /hr)	4,300	

## COMPRESSOR

TYPE	Hermetic type, 2 pole, 3-phase, Induction motor		
CODE	ZRT122K3E-TFD		
REFRIGERANT	(R407C)	(g)	7,000

## FAN MOTOR

MODEL NO.		RD-90EA	RD-90TA	RO-90EPA	RO-90TPA
TYPE		MFA-90GQH		MFB-90FTH	
POWER SOURCE	(V)	380 - 415		220 - 240	
HI-SPEED	(r.p.m.)	1,140		730	
LO-SPEED	(r.p.m.)	—		360	

## DIMENSIONS

H x W x D	(mm)	450 x 1,550 x 700	1,380 x 1,300 x 650
-----------	------	-------------------	---------------------

## WEIGHTS

GROSS / NET	(kg)	100 / 85	280 / 243	282 / 245
-------------	------	----------	-----------	-----------

## ADDITIONAL REFRIGERANT CHARGE

PIPE LENGTH		30m	40m	50m
FULL CHARGE AMOUNT		7,000g	8,000g	9,000g

- Note :
- Between 30 m and 50 m, when using a connection pipe other than that in the table, charge additional refrigerant with 100 g/1 m as the criteria.
  - The above list shows values at the external static pressure of 20 mm Aq. (196 Pa).

# OUTLINE AND DIMENSIONS

Models : RD-90EA  
RD-90TA

(Unit : mm)

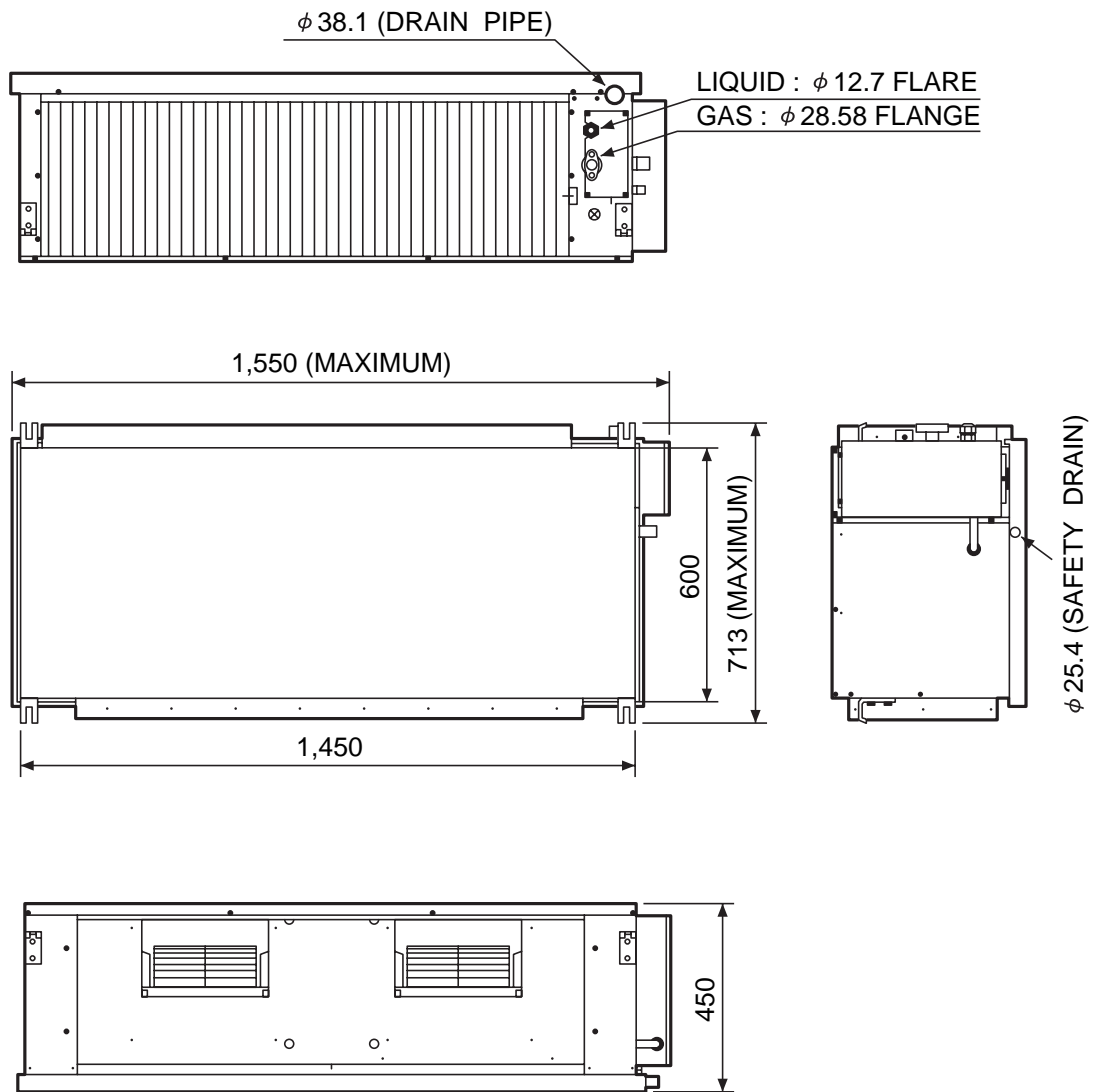

Models : RO-90EPA  
RO-90TPA

(Unit : mm)

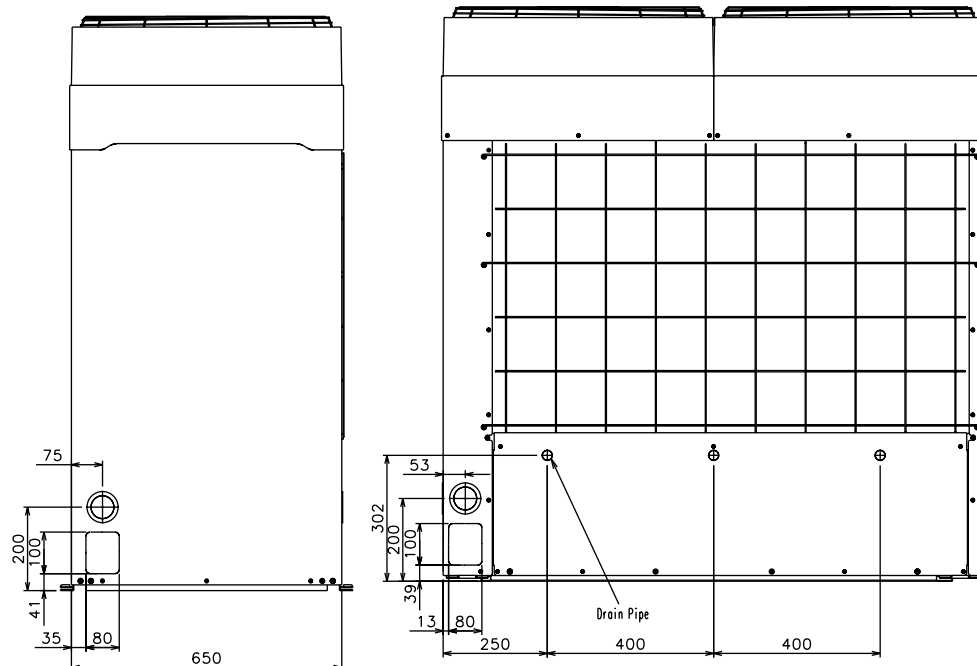
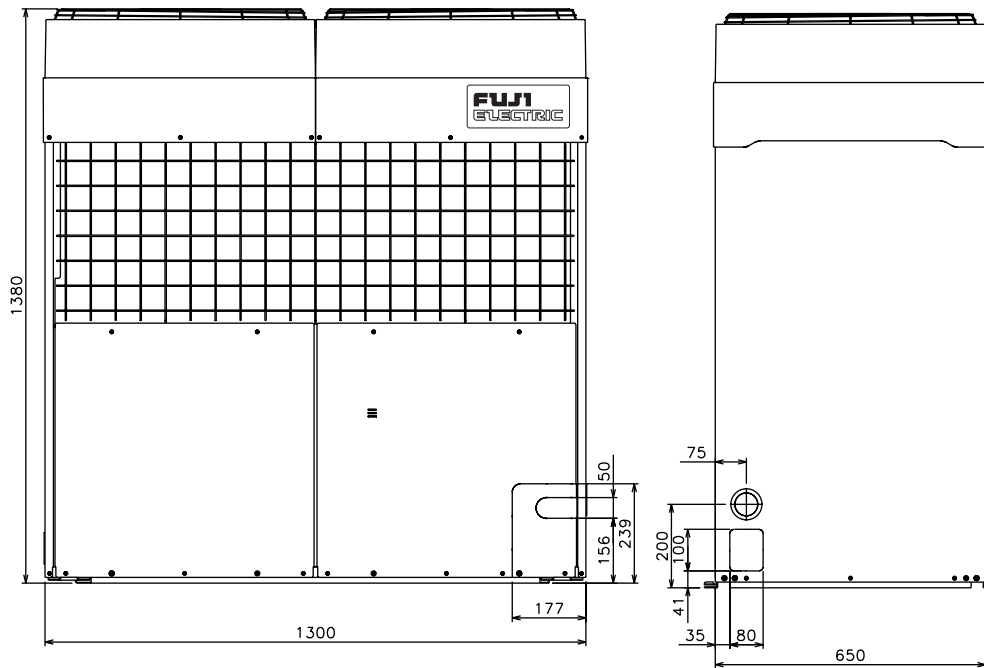
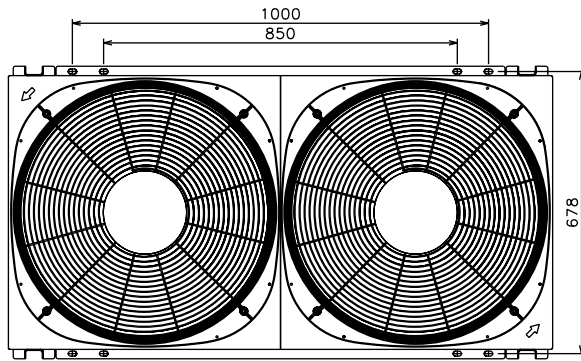

## SERVICE SPACE FOR OUTDOOR UNIT

- Height of side wall is free.
- Height (H) of front wall is less than 1,200mm.
- When total height of outdoor unit is lower than front wall, add dimension h to service space for dimensions L1 and L2.

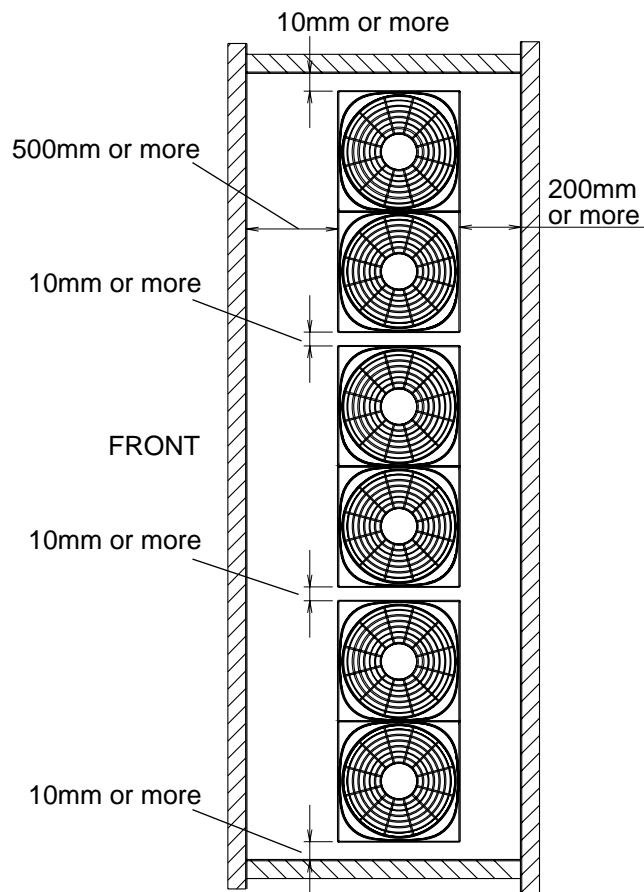
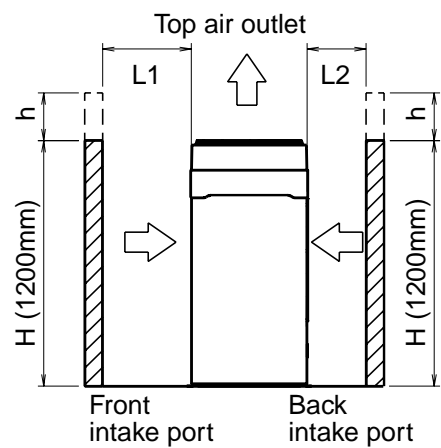
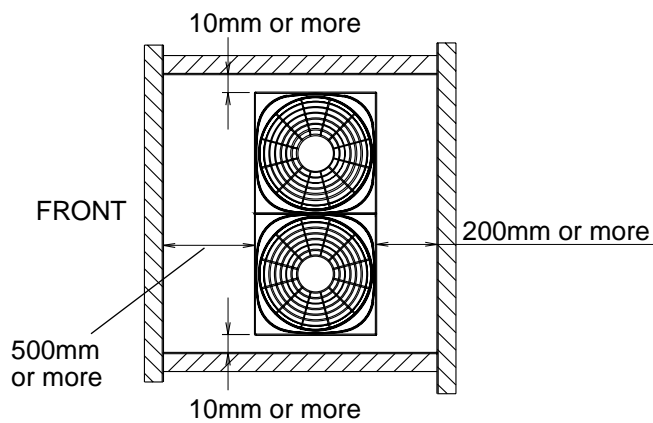

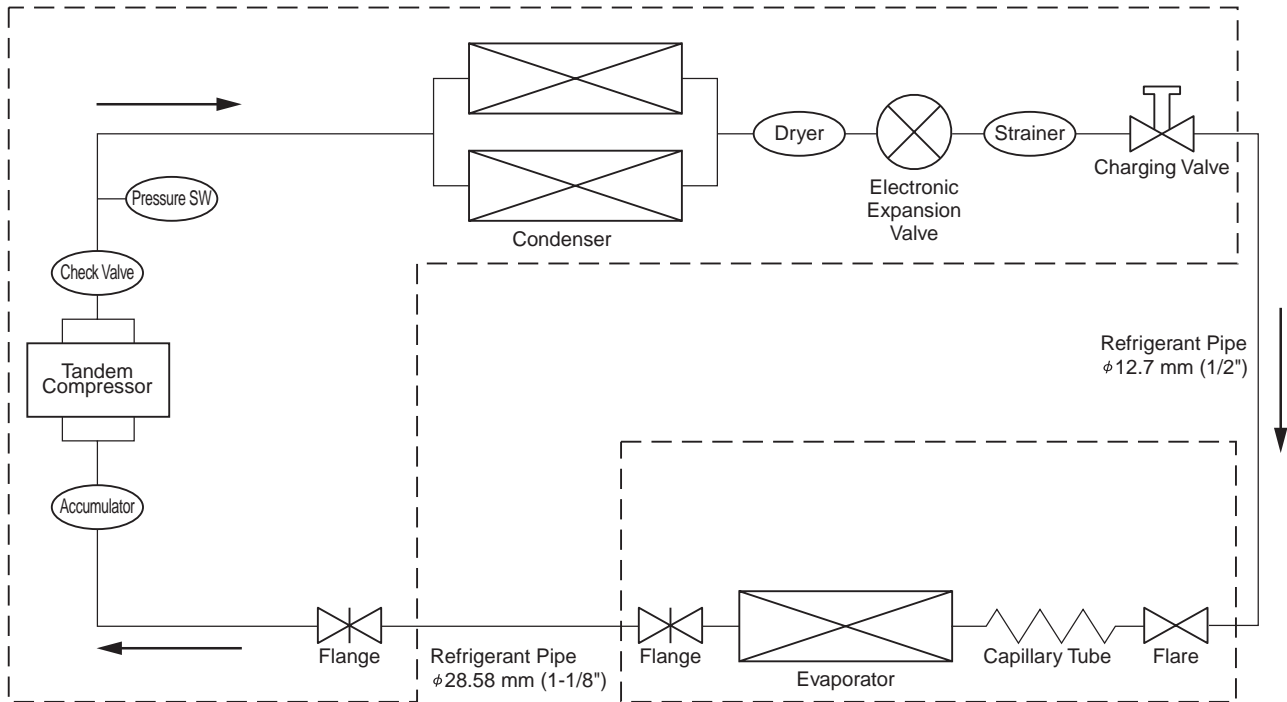

# REFRIGERANT SYSTEM DIAGRAM

**Models : RD-90EA / RO-90EPA**

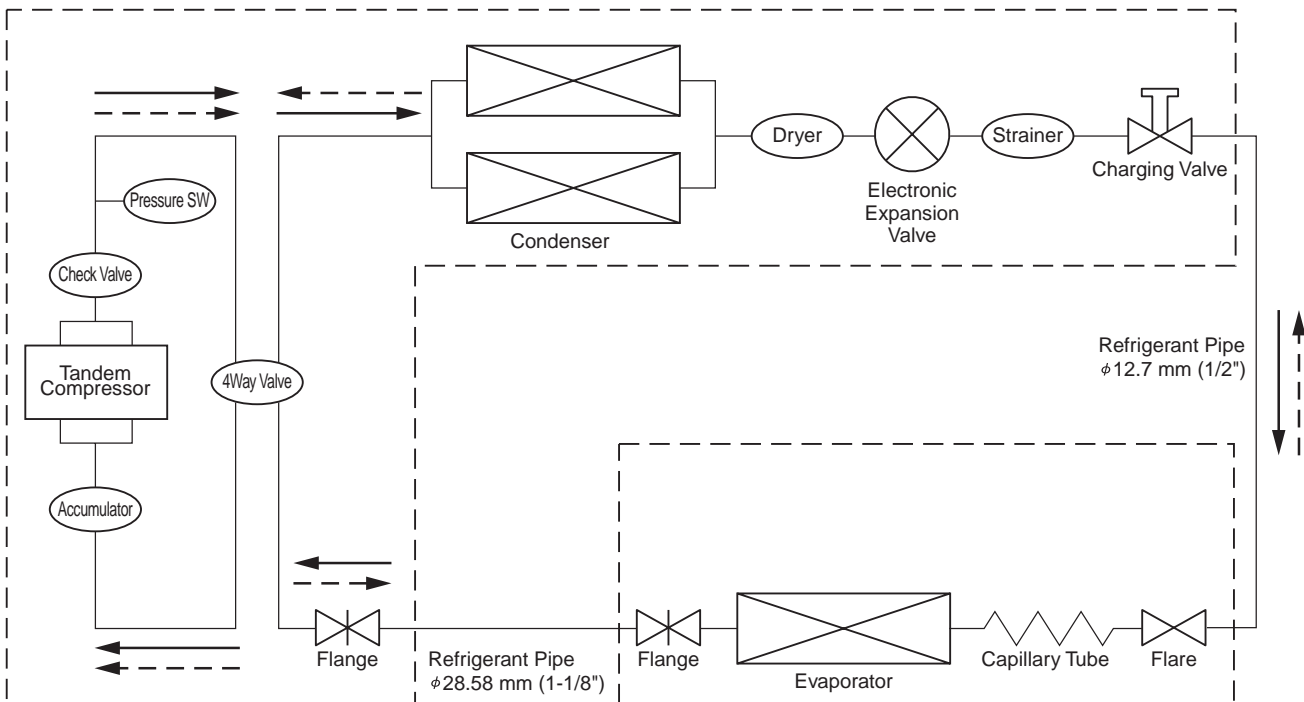

**Models : RD-90TA / RO-90TPA**



 Cooling  
 Heating

# CIRCUIT DIAGRAM

Models : RD-90EA  
RD-90TA

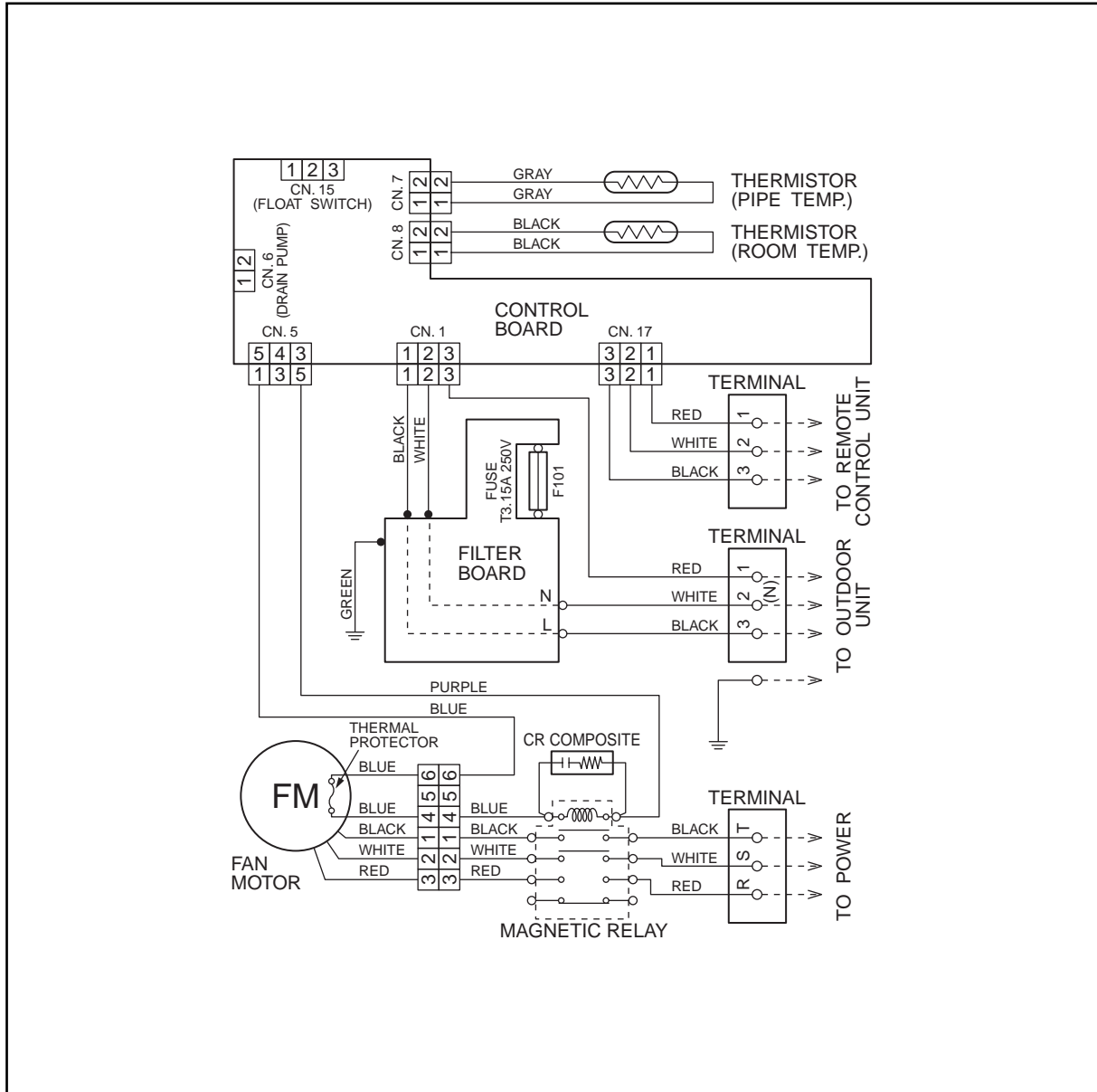

**Model : RO-90EPA**

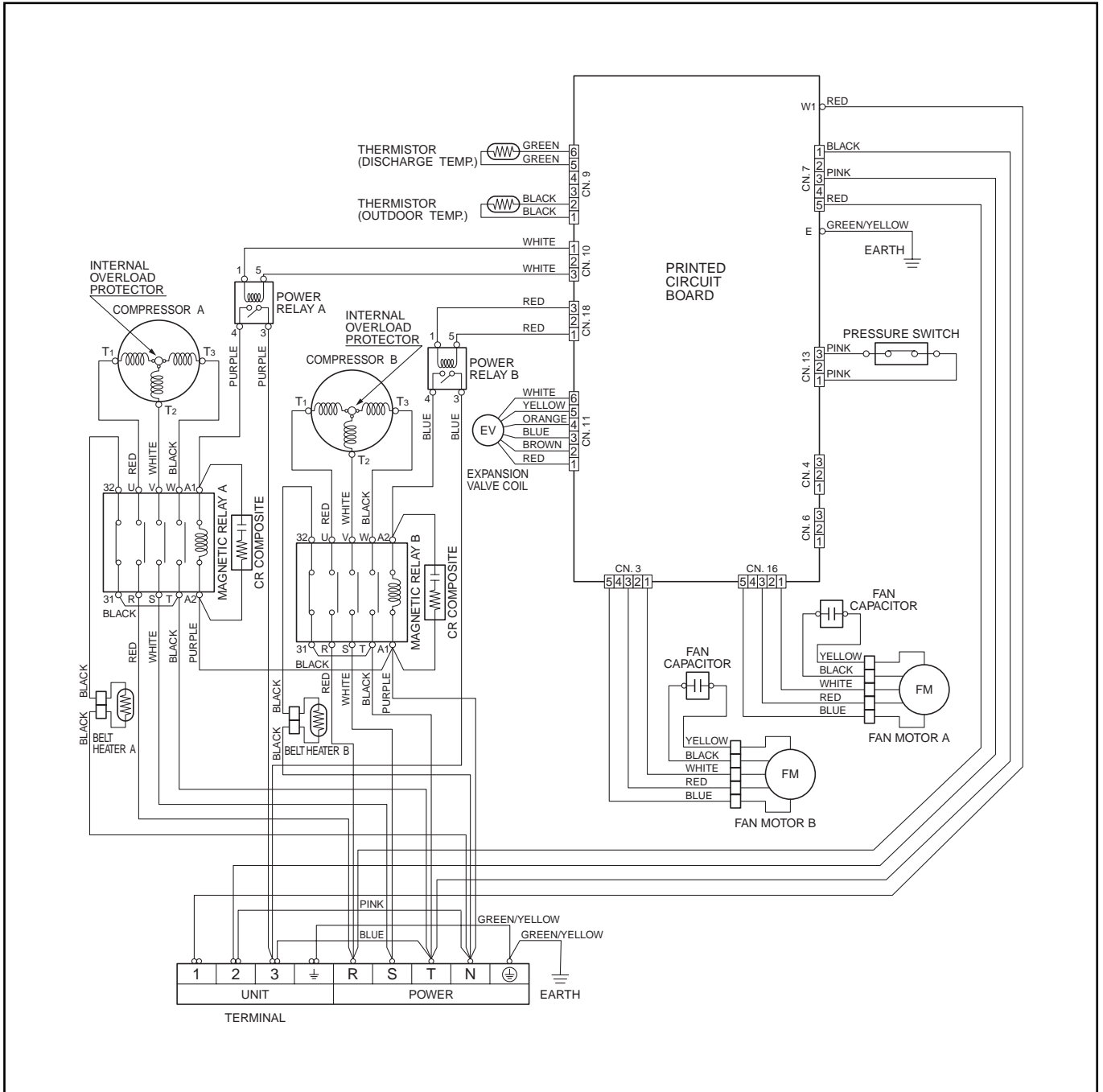



**Model : RO-90TPA**

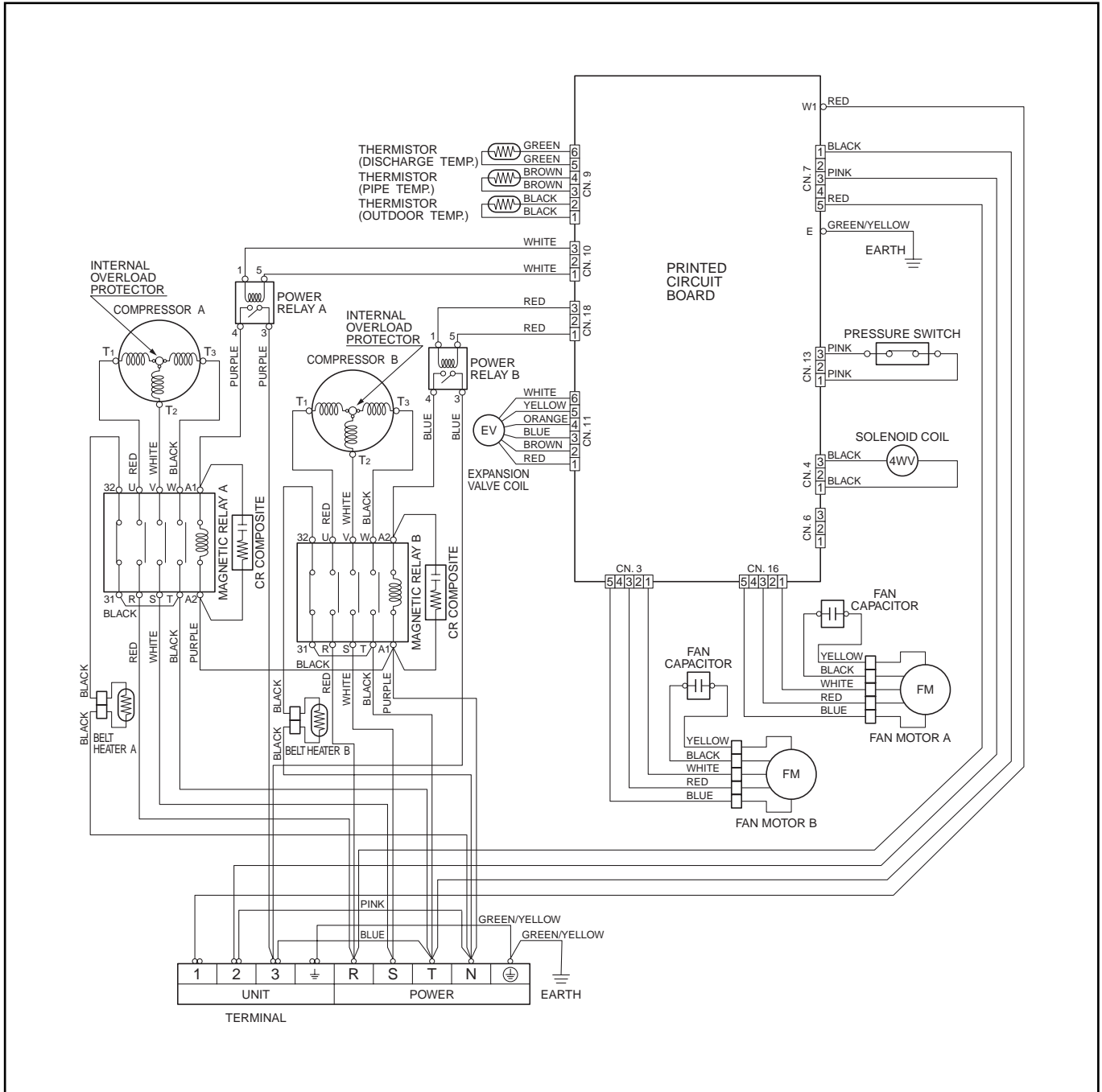

# INDOOR PRINTED CIRCUIT BOARD CIRCUIT DIAGRAM

Model : RD-90EA

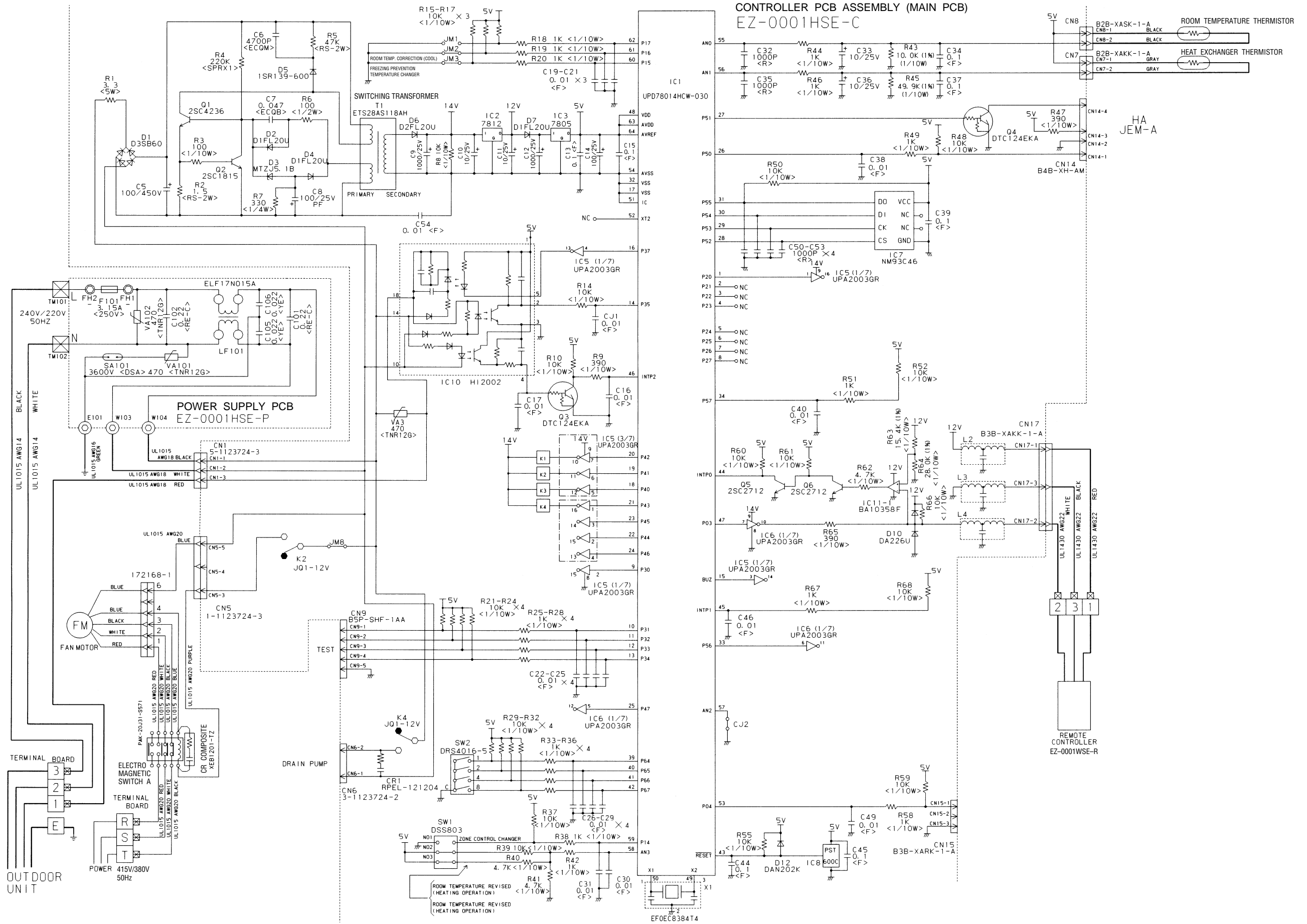

Model : RD-90TA

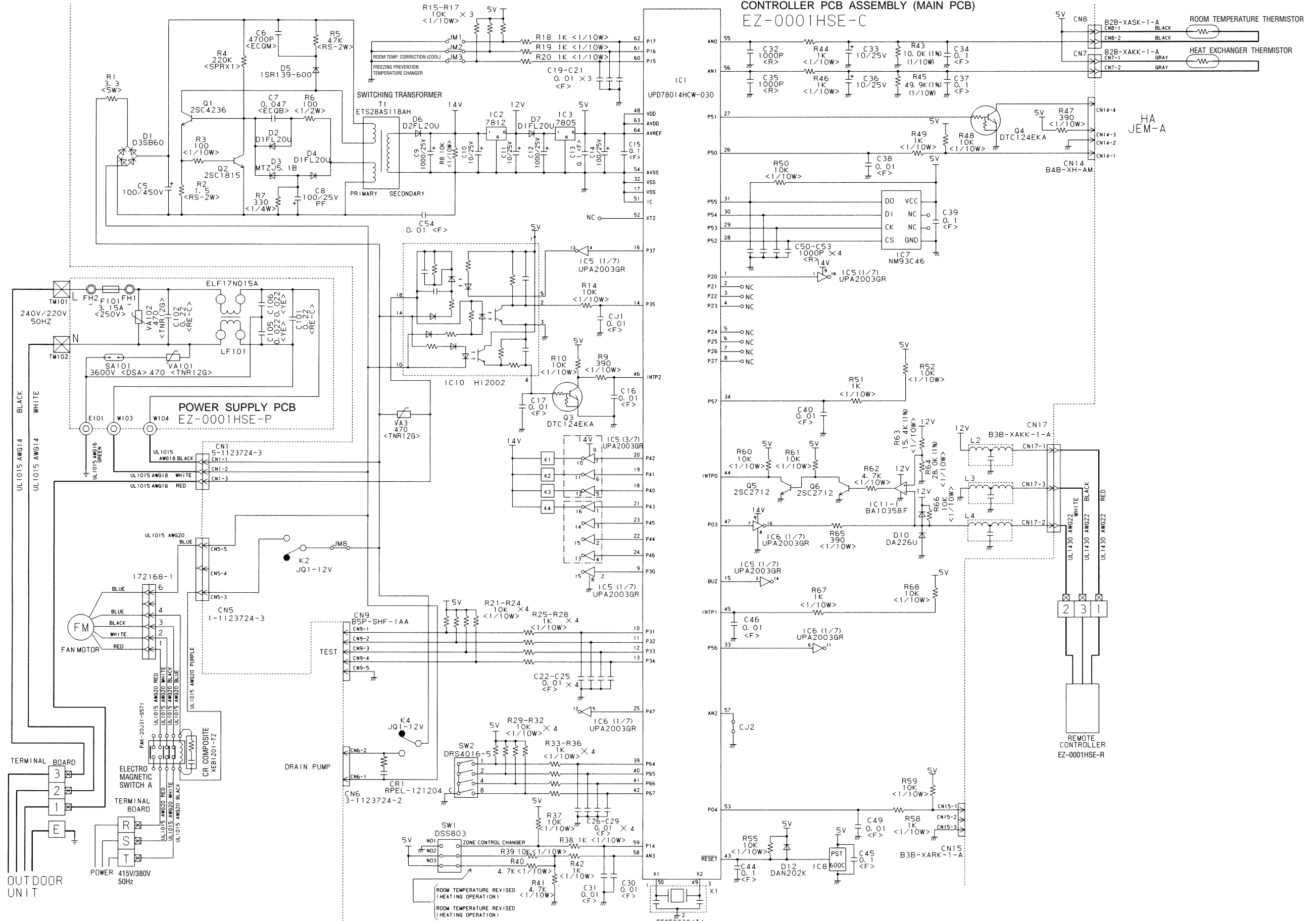

# OUTDOOR PRINTED CIRCUIT BOARD CIRCUIT DIAGRAM

Model : RO-90EPA

CONTROLLER PCB ASSEMBLY (MAIN PCB)

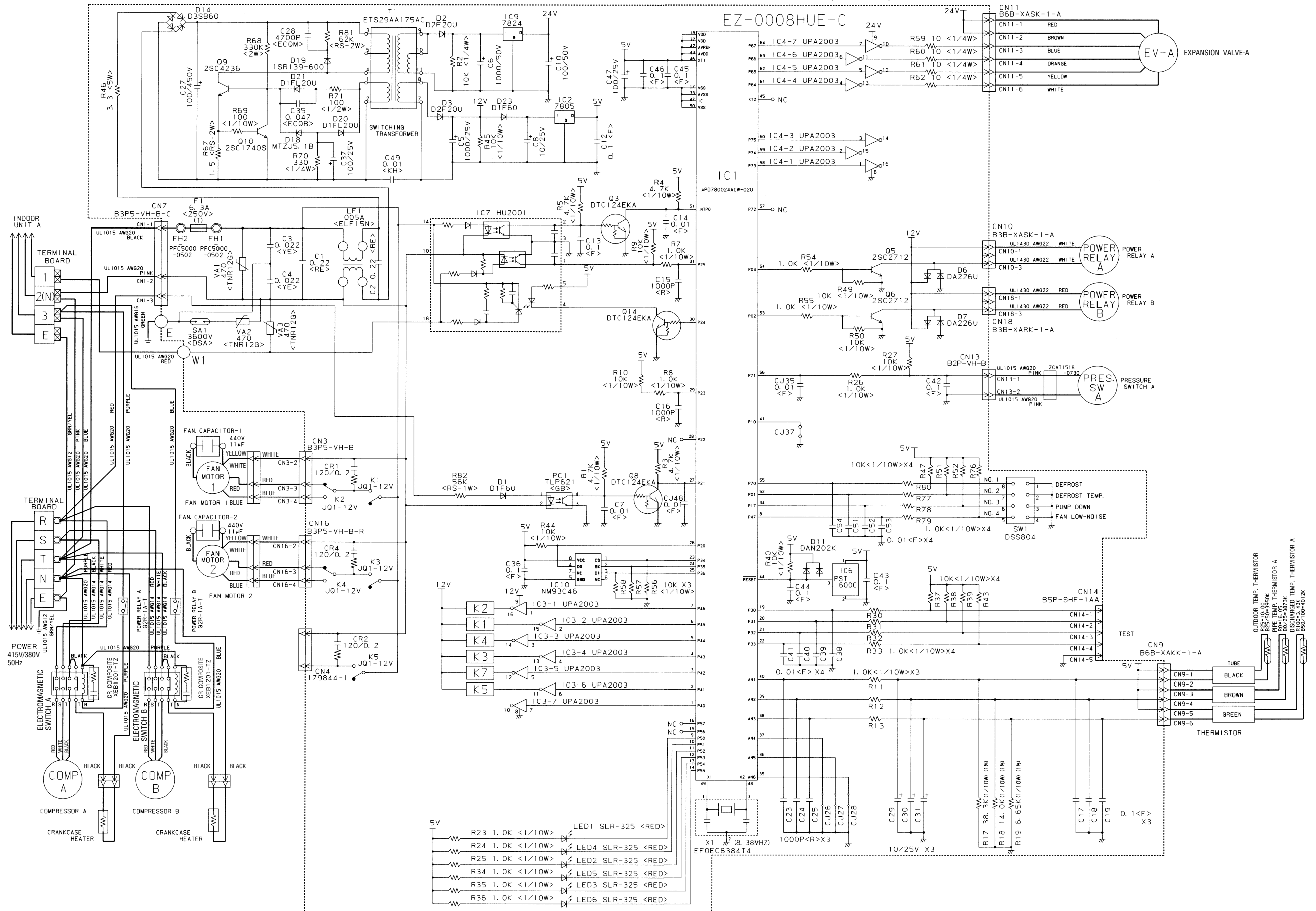

Model : RO-90TPA

CONTROLLER PCB ASSEMBLY (MAIN PCB)

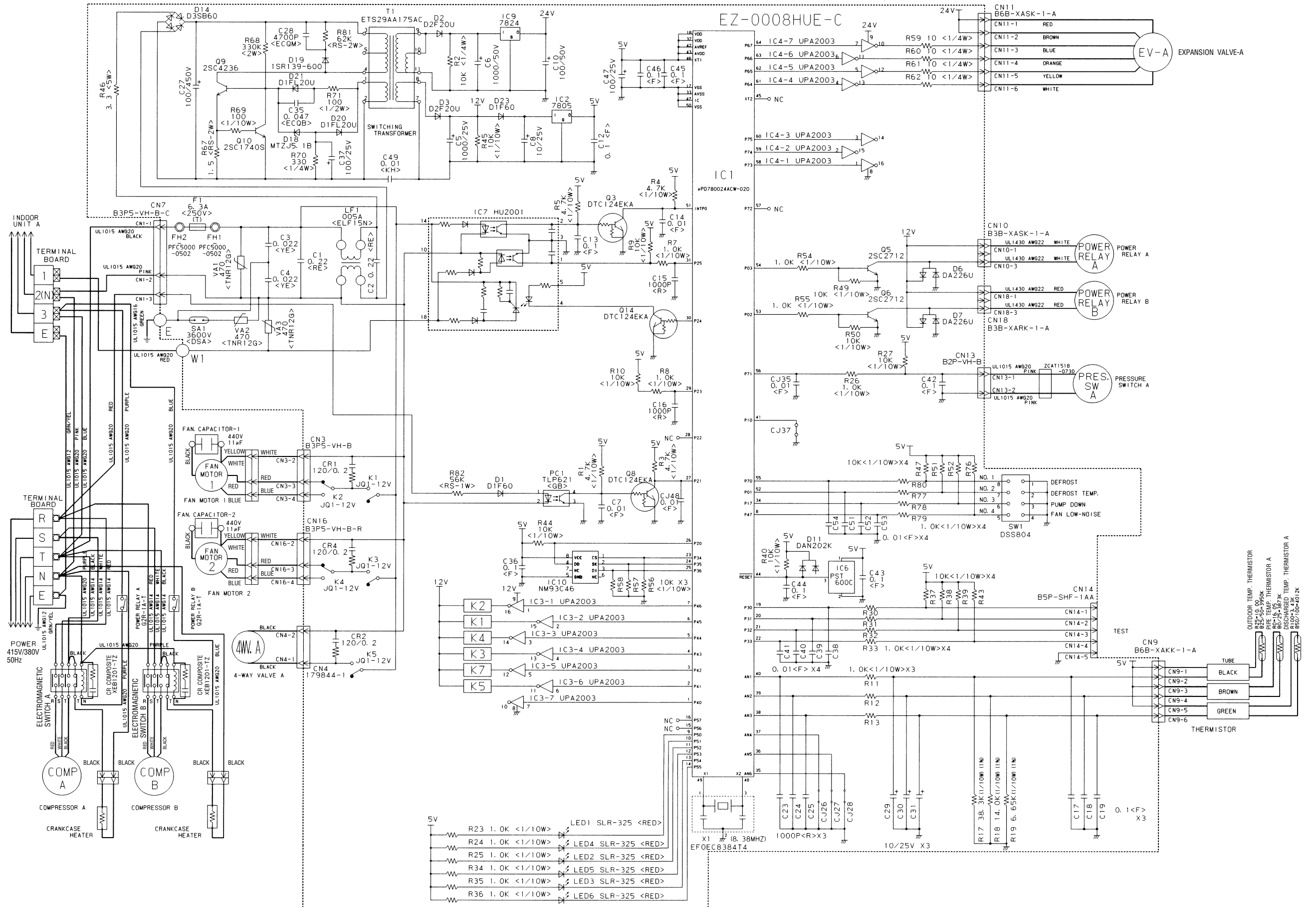

# INDOOR P.C. BOARD LAYOUTS

## CONTROLLER P.C. BOARD ASSEMBLY (MAIN PCB)

(Viewed from the component side)

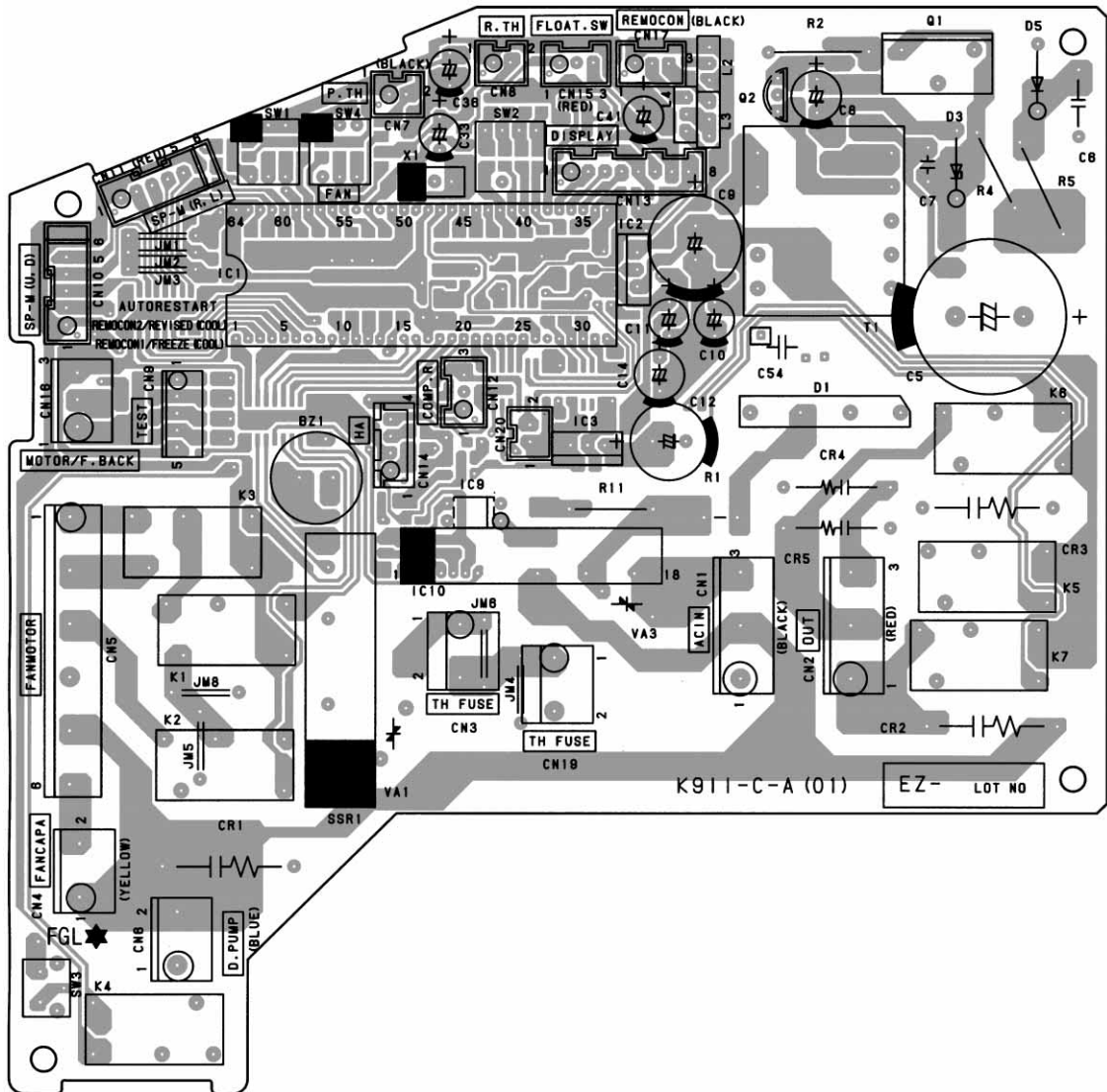

## FILTER P.C. BOARD ASSEMBLY (MAIN PCB)

(Viewed from the component side)

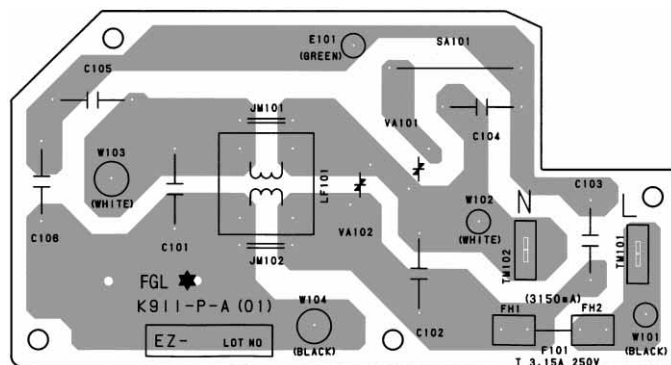

## CONTROLLER P.C. BOARD ASSEMBLY (MAIN PCB)

(Viewed from the solder side)

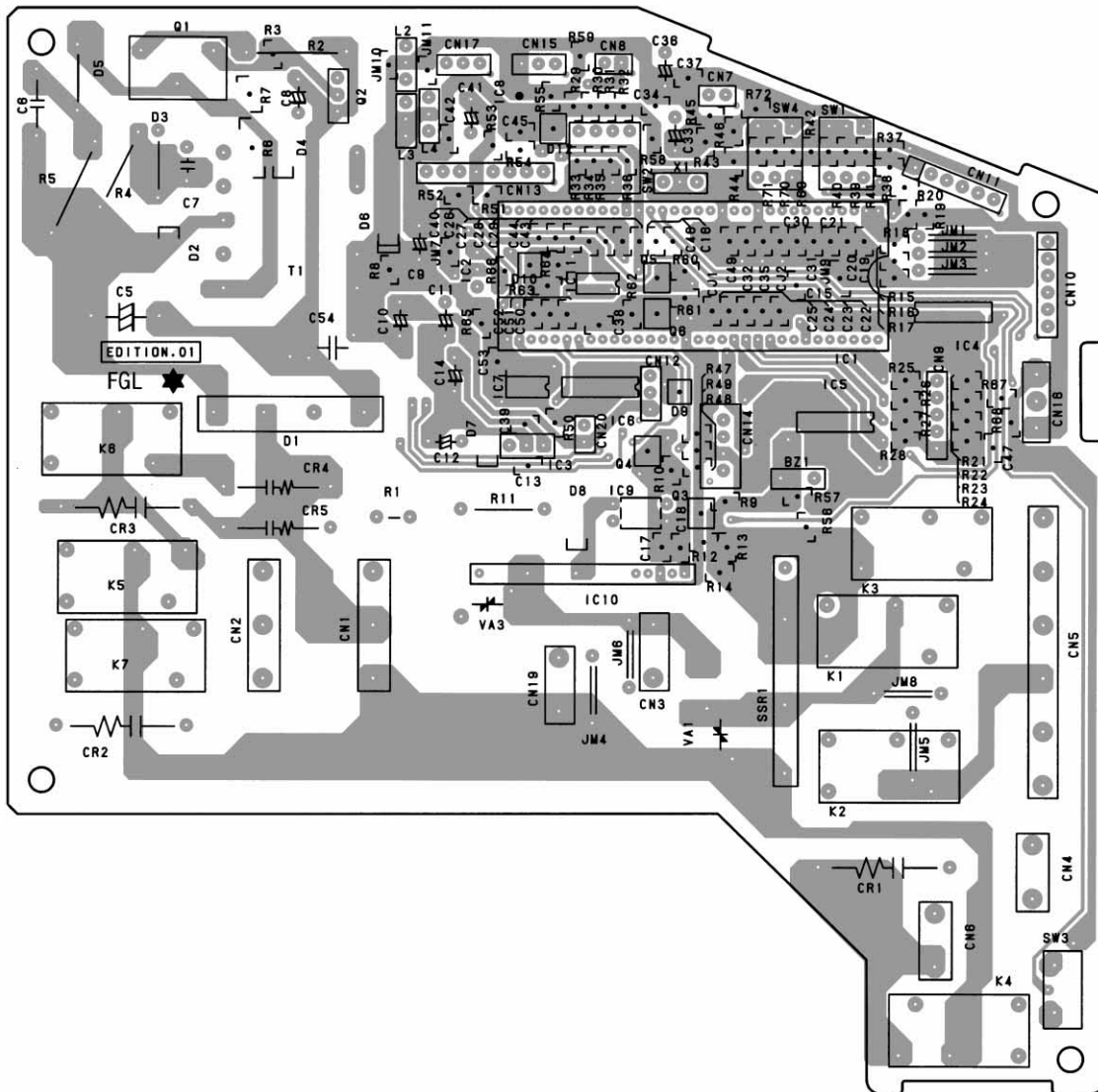

## FILTER P.C. BOARD ASSEMBLY (MAIN PCB)

(Viewed from the solder side)

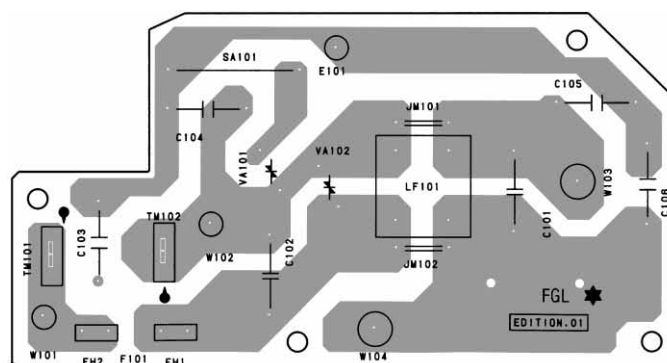

# OUTDOOR P.C. BOARD LAYOUTS

## CONTROLLER P.C. BOARD ASSEMBLY (MAIN PCB)

(Viewed from the component side)

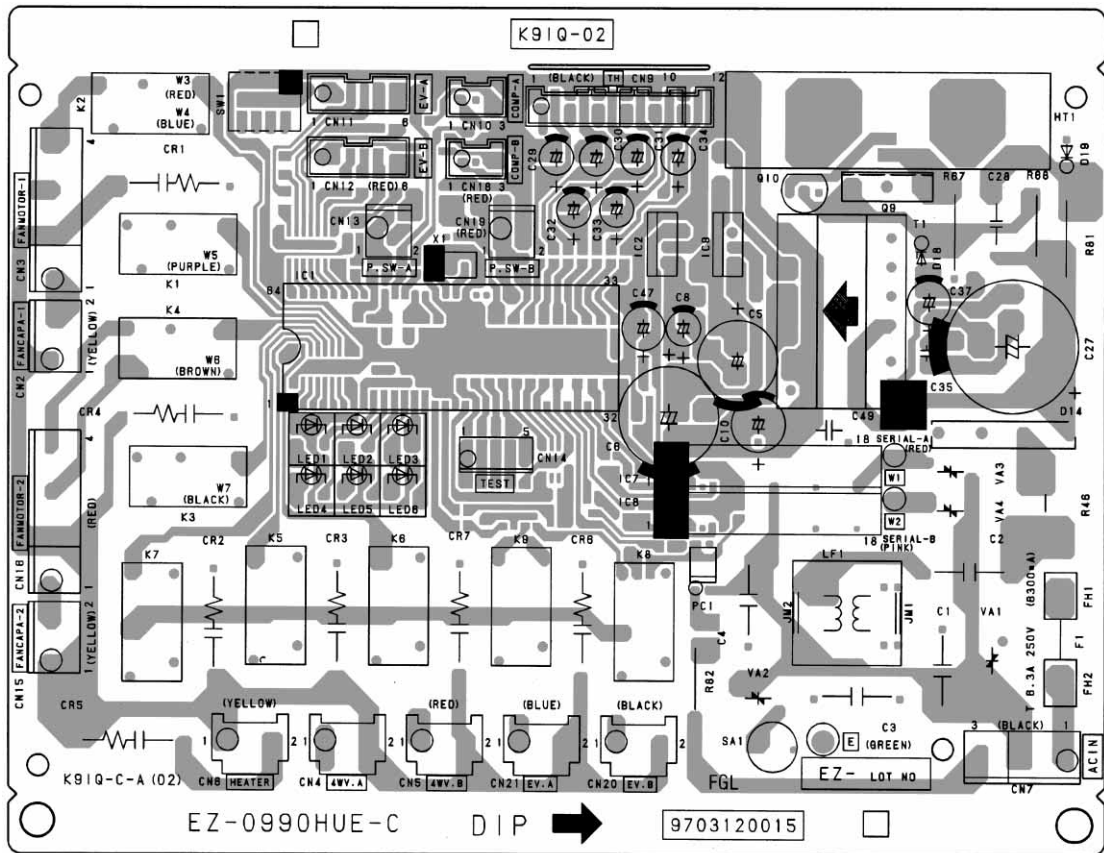

(Viewed from the solder side)

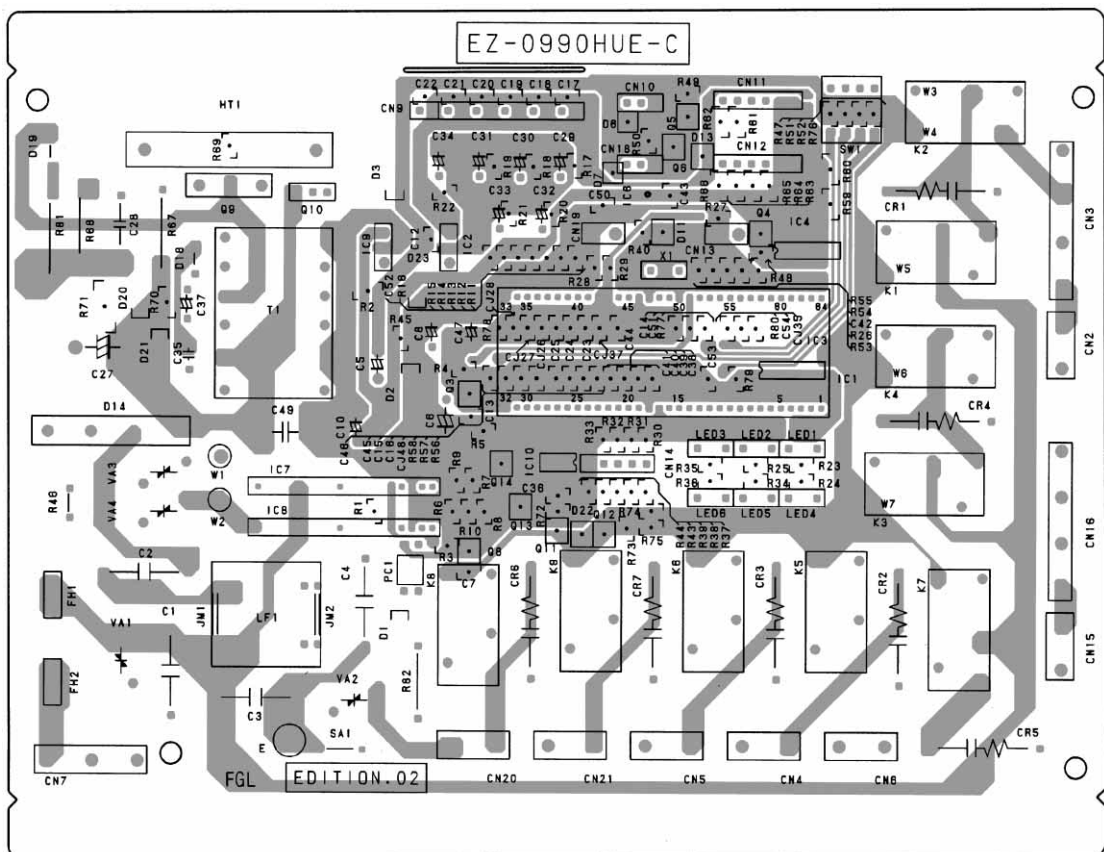



# DISASSEMBLY ILLUSTRATION

Models : RO-90EPA  
RO-90TPA

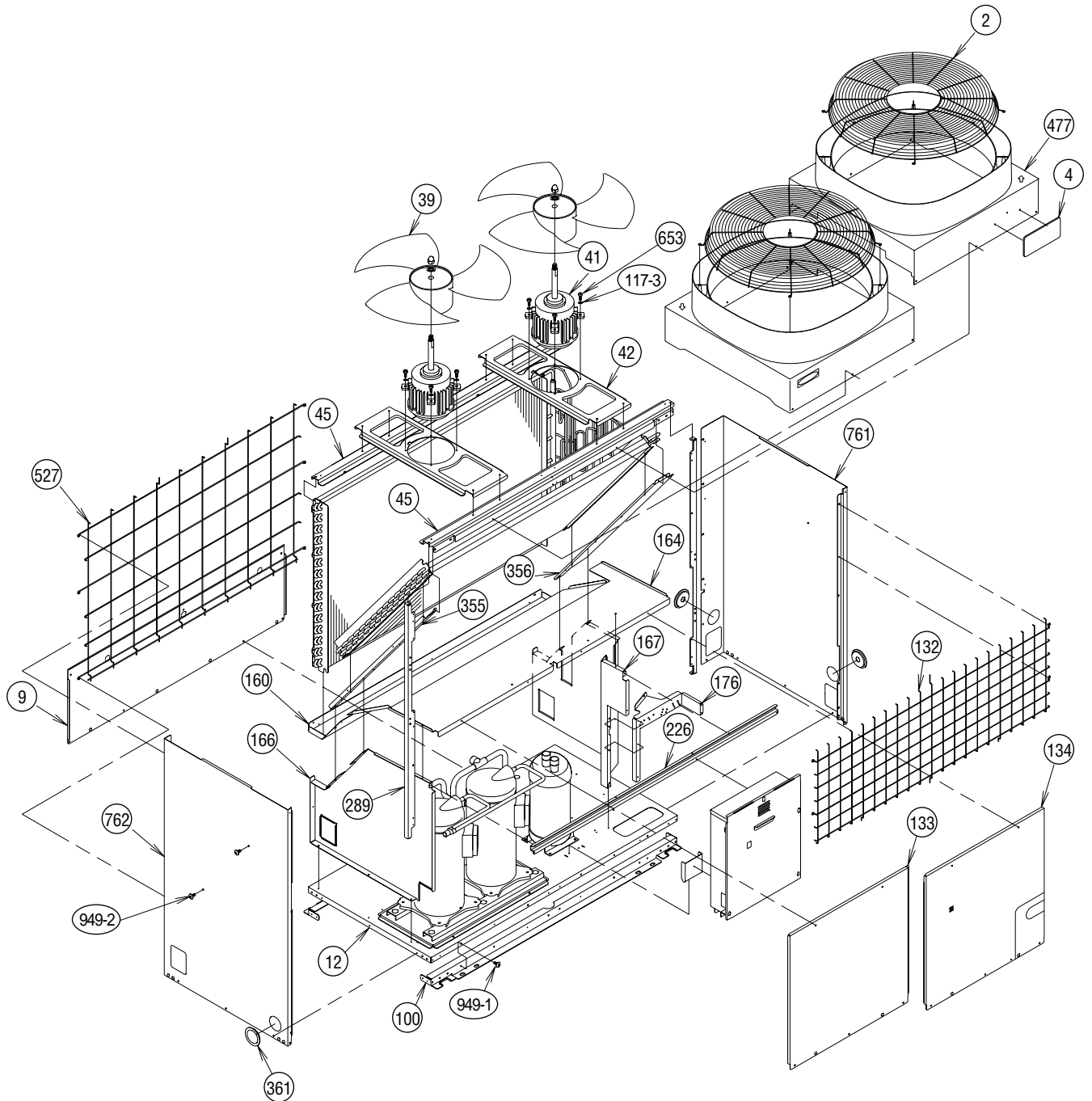

**Model : RO-90EPA**

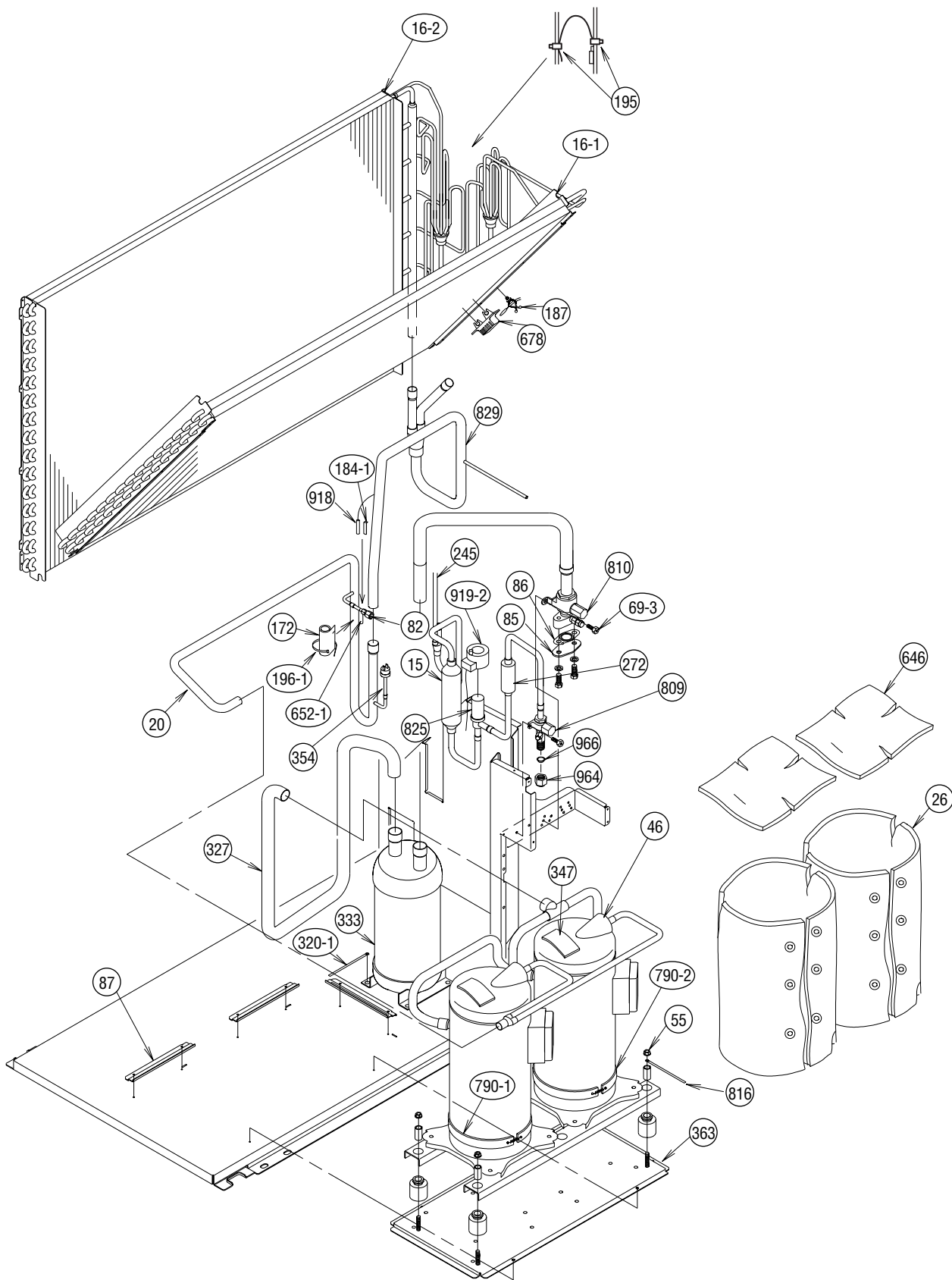

**Model : RO-90TPA**

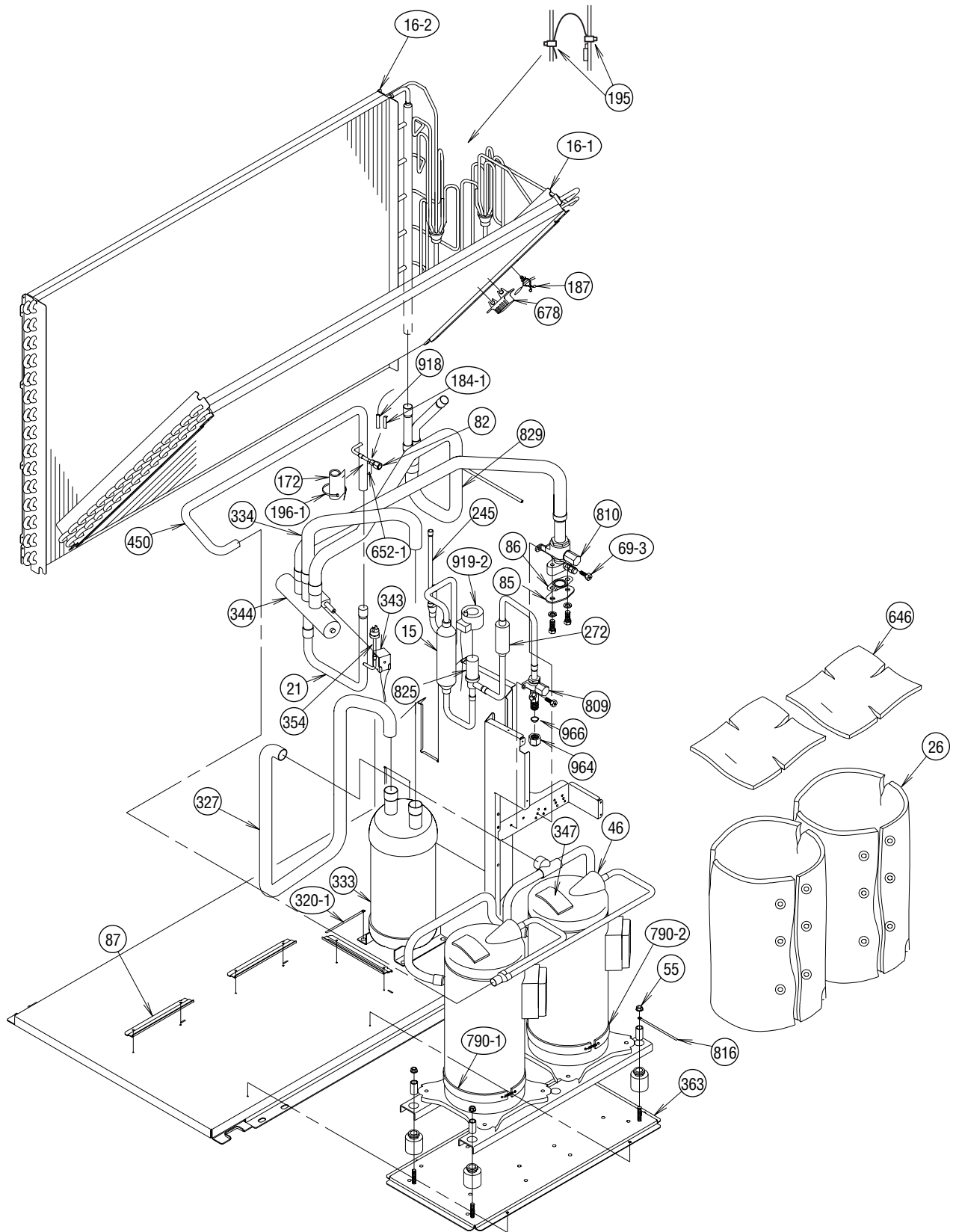

Models : RO-90EPA  
RO-90TPA

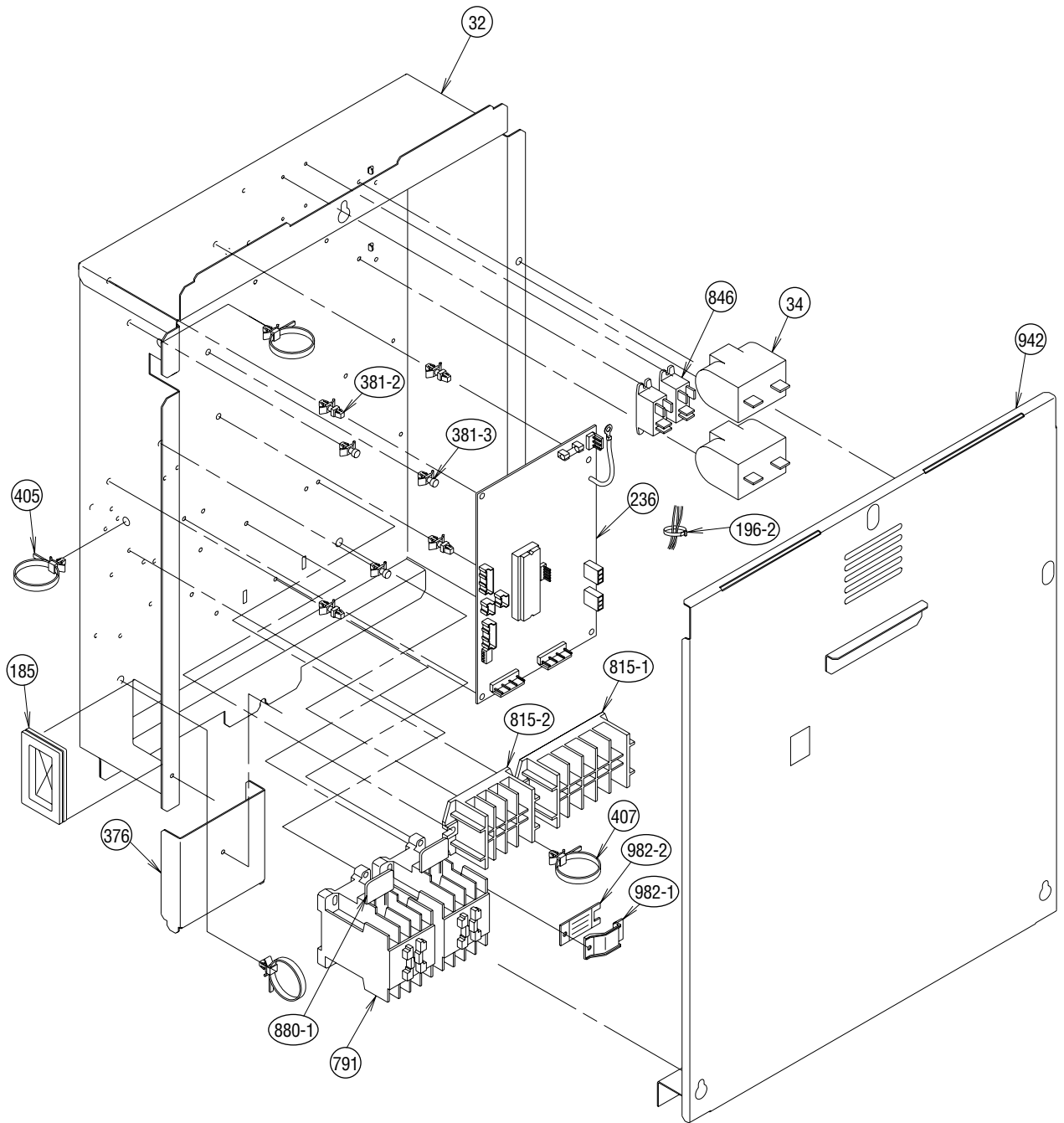

Models : RD-90EA  
RD-90TA

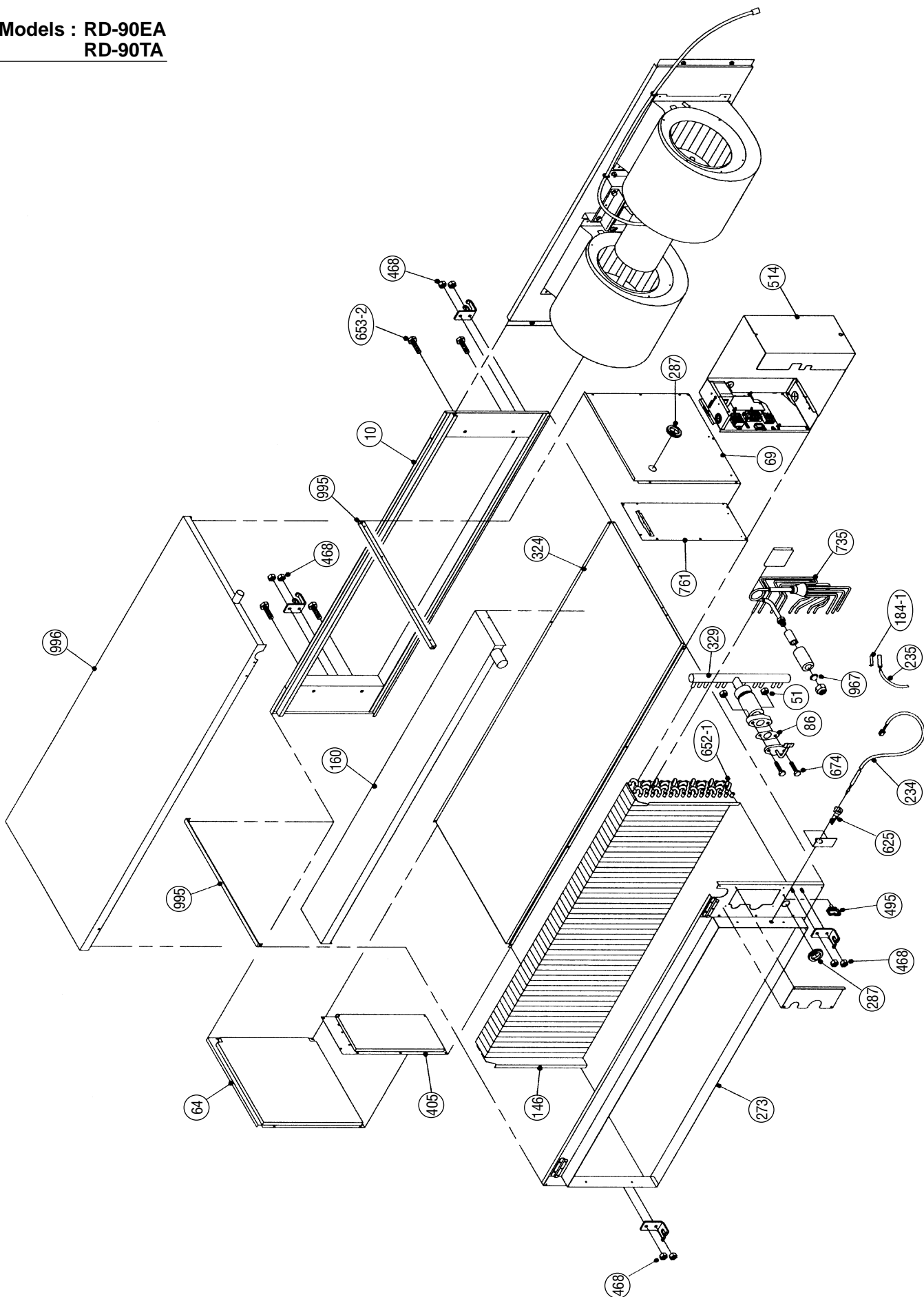

Models : RD-90EA  
RD-90TA

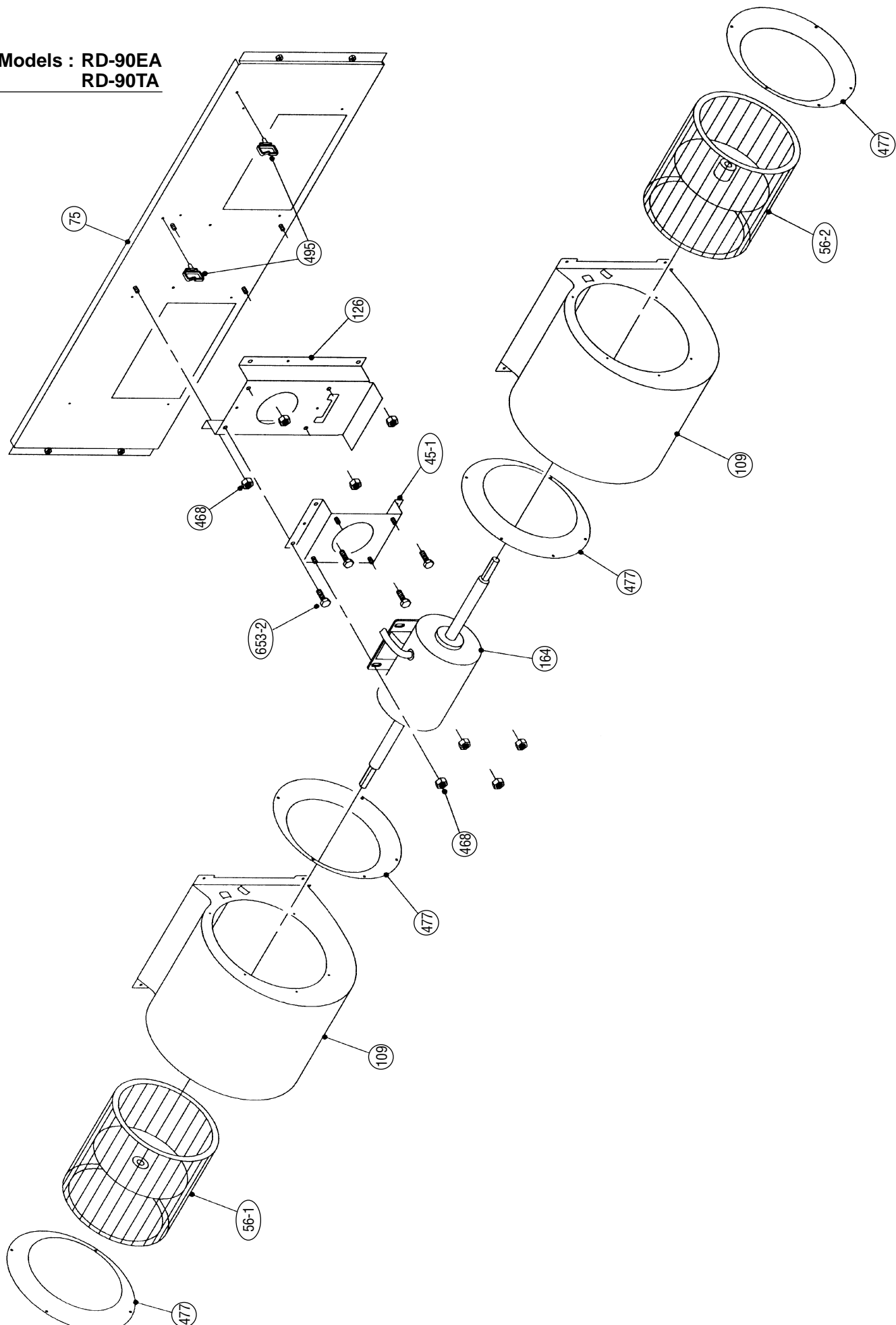

Models : RD-90EA  
RD-90TA

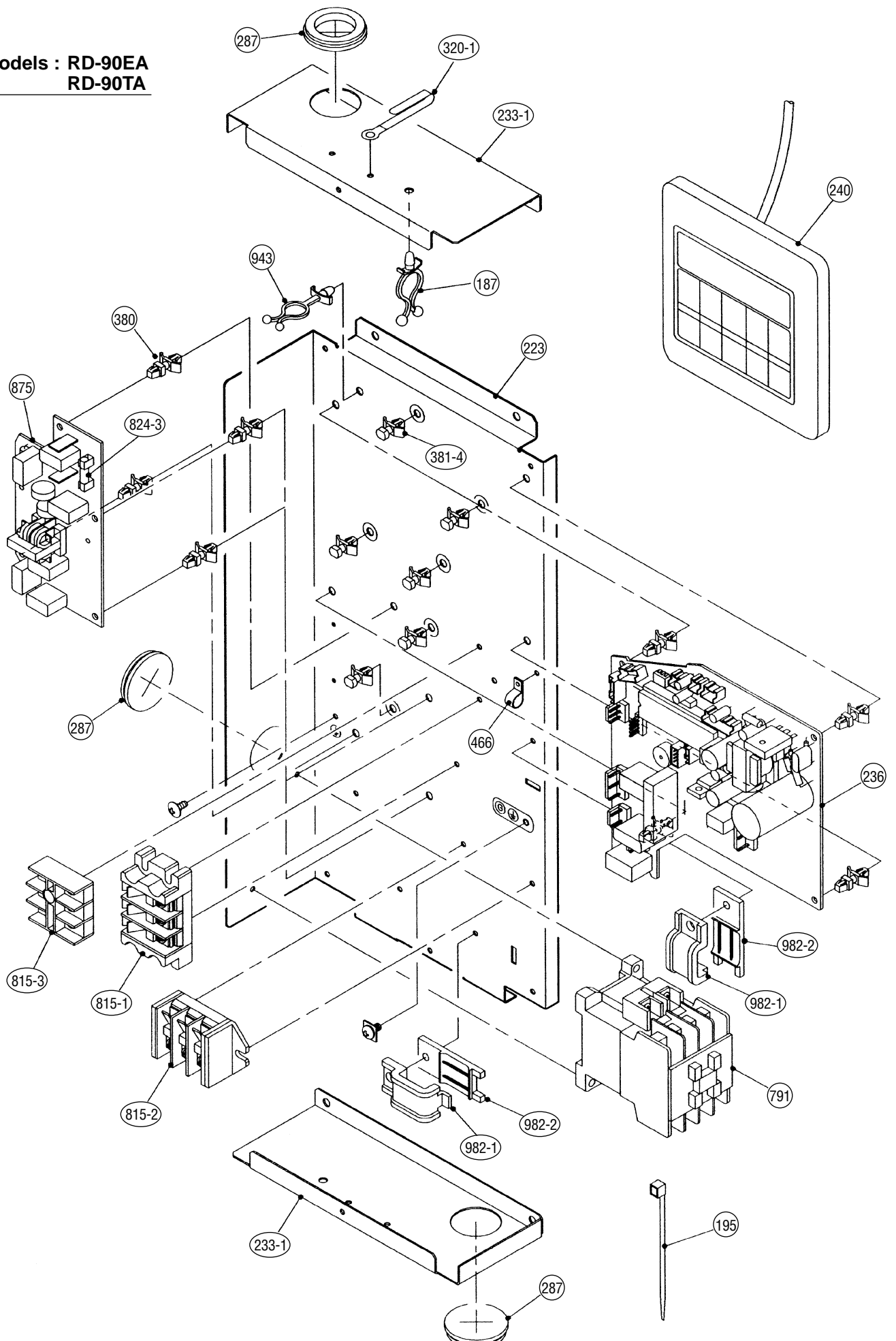

# PARTS LIST

When you order parts, please make a photocopy of this page and fill the number of the parts in the "Order" column.

## OUTDOOR UNIT

Ref. No.	Description	Part No.		Ord. Q'ty	Ref. No.	Description	Part No.		Ord. Q'ty
		RO-90EPA	RO-90TPA				RO-90EPA	RO-90TPA	
2	Fan Cover	9366142010	9366142010		327	Suction Pipe - A	9365599006	9365599006	
4	Emblem-Rear "FUJI"	9301702019	9301702019		333	Accumulator	9361939004	9361939004	
9	Rear Panel, Painted	9361712027	9361712027		334	Suction Pipe - B	—	9361894006	
12	Base Assy	9361684003	9361684003		343	Solenoid Coil	—	9703342011	
15	Dryer	9361926004	9361926004		344	4-Way Valve	—	9703270000	
16-1	Condenser-A Assy	9363299014	9363299014		347	Noise Insulation - D	313712304109	313712304109	
16-2	Condenser-B Assy	9363300017	9363300017		354	Pressure Switch	9703667008	9703667008	
20	Discharge Pipe Assy	9365569009	—		355	Bracket (Condenser) - L	9361698000	9361698000	
21	Discharge Pipe - B Assy	—	9365567005		356	Bracket (Condenser) - R	9361699007	9361699007	
26	Compressor Cover-A	9361935006	9361935006		361	Bushing	9361725003	9361725003	
32	Control Box	9361713000	9361713000		363	Bracket Panel (Comp.)	9361691018	9361691018	
34	Capacitor (Fan Motor)	9703306037	9703306037		376	Bracket (Control Box)	9361727007	9361727007	
39	Propeller Fan	9361726000	9361726000		381-2	Locking Spacer KGLS-8S	0600035020	0600035020	
41	Fan Motor Assy-Outer	9600882009	9600882009		381-3	Locking Spacer KGPS-8S	0600118051	0600118051	
42	Bracket Panel (Motor)	9361703001	9361703001		405	Clamp No.1763	313816345304	313816345304	
45	Bracket (Motor)	9361701007	9361701007		407	Clamp(Cable) No.1259	313739340109	313739340109	
46	Compressor Assy	9361876002	9361876002		450	Discharge Pipe - A Assy	—	9363024005	
55	Special Nut M8	313252257701	313252257701		477	Bellmouth	9361721005	9361721005	
69-3	Bolt , Hex.Socket	301210060360	301210060360		527	Condenser Guard	9366143017	9366143017	
82	Check Joint Assy	9363886009	9363886009		646	Compressor Cover - B	9361936003	9361936003	
85	Valve Plate	9363063004	9363063004		652-1	Thermistor Holder Pipe	313714262805	313714262805	
86	Gasket	9363272000	9363272000		653	Bolt, For Fan Motor	0700145087	0700145087	
87	Bracket (Compressor)	9361694002	9361694002		678	Bracket (Thermistor)	313557406106	313557406106	
100	Base Foot , Painted	9361688025	9361688025		761	Side Panel - R, Painted	9361706026	9361706026	
117-3	Special Washer M6	313306391007	313306391007		762	Side Panel - L, Painted	9361705029	9361705029	
132	Front Protection Net	9366144014	9366144014		790-1	Belt Heater - A	9361140042	9361140042	
133	Front Panel - L	9361709027	9361709027		790-2	Belt Heater - B	9361140059	9361140059	
134	Front Panel - R	9361710047	9361710047		791	Magnetic Relay	9363277005	9363277005	
160	Drain Pan	9361700000	9361700000		809	Ball Valve - A	9361937000	9361937000	
164	Separate Wall - Upper	9361693005	9361693005		810	Ball Valve - B	9361938007	9361938007	
166	Separate Wall - L	9361695009	9361695009		815-1	Terminal 5P	9363275018	9363275018	
167	Separate Wall - R	9361696006	9361696006		815-2	Terminal 4P	9363276015	9363276015	
172	Pipe Cover	9363470000	9363470000		816	Wire Clamp Metal	313584219902	313584219902	
176	Bracket (Valve) - A	9361719002	9361719002		825	Expansion Valve Assy	9365566008	9365566008	
184-1	Thermostat Spring-A	313728262708	313728262708		829	Joint Pipe Assy	9362922005	9361886001	
185	Rubber Bushing	313005066051	313005066051		846	Relay	9304375005	9304375005	
187	Clamp No.1219	313361271706	313361271706		880-1	Network (C - R)	9700987017	9700987017	
195	Clamp SKB - 100	313361275805	313361275805		918	Thermistor Assy	9703129018	9703129018	
196-1	Clamp SKB - 3M	312300787605	312300787605		919-2	Expansion Valve Coil	9361930001	9361930001	
196-2	Clamp SKB - 150	313035356905	313035356905		942	Control Box Cover	9361716001	9361716001	
226	Reinforcement (Separate Wall)	9361697003	9361697003		949-1	Screw, Painted	9305648009	9305648009	
236	Controller PCB Assy	9703684012	9703684012		949-2	Screw, Painted	9302348001	9302348001	
245	Condensing Pipe - M	9363031003	9363031003		964	Flare Nut	9363273007	9363273007	
272	Strainer	9361931008	9361931008		966	Bonnet	9363274004	9363274004	
289	Reinforcement (Side Panel)	9361704008	9361704008		982-1	Cord Clamp	9356857009	9356857009	
320-1	Wire Clamp Metal	313483219905	313483219905		982-2	Cord Clamp - B	9356858006	9356858006	



When you order parts, please make a photocopy of this page and fill the number of the parts in the "Order" column.

## INDOOR UNIT

Ref. No.	Description	Part No.		Ord. Q'ty	Ref. No.	Description	Part No.		Ord. Q'ty
		RD-90EA	RD-90TA				RD-90EA	RD-90TA	
10	Front Panel Assy	9364635002	9364635002		329	Coupling Pipe Assy	9365347003	9365347003	
45-1	Bracket (Motor) Assy	9364630007	9364630007		380	Locking Spacer KGLS-6S	313209391403	313209391403	
51	Nut	0700005091	0700005091		381-4	Locking Spacer KGPS-6S	0600118075	0600118075	
56-1	Sirocco Fan-R	9364665016	9364665016		405	Panel Side	9364648002	9364648002	
56-2	Sirocco Fan-L	9364665023	9364665023		466	Clamp NK-4N	313714328805	313714328805	
64	Left Panel	9364650005	9364650005		468	Nut-A M8	9356998009	9356998009	
69	Right Panel	9364649009	9364649009		477	Bellmouth	9364664002	9364664002	
75	Fan Panel	9364629001	9364629001		495	Clamp No.2U46	9352715006	9352715006	
86	Gasket	9363272000	9363272000		514	Control Box Cover Metal	9365186008	9365186008	
109	Casing Assy	9364660004	9364660004		625	Cord Bushing	9359240006	9359240006	
126	Motor Plate Assy	9364632001	9364632001		652-1	Therm. Holder Pipe	313806262805	313806262805	
146	Evaporator Assy	9364672007	9364672007		653-2	Bolt HLSJ8025ZV	0700190018	0700190018	
160	Drain Pan Assy	9364652023	9364652023		674	Bolt LSM10045	0700145117	0700145117	
164	Fan Motor Assy-In	9601004004	9601004004		735	Distributor Assy	9365343005	9365343005	
184-1	Thermo. Spring-A	313728262708	313728262708		761	Side Panel-R Assy	9365147009	9365147009	
187	Clamp No.1219	313361271706	313361271706		791	Magnetic Relay	9363277005	9363277005	
195	Clamp SKB-100	313361275805	313361275805		815-1	Terminal 3P	9356488005	9356488005	
223	Control Box Metal	9365185001	9365185001		815-2	Terminal 3P	9363276046	9363276046	
233-1	Plate (Box)	9365146002	9365146002		815-3	Terminal 3P	9703345012	9703345012	
234	Thermistor Assy-Room	9703299056	9703299056		824-3	Fuse	0600285210	0600285210	
235	Thermistor Assy-Pipe	9703297021	9703297021		875	Filter PCB Assy	9703402029	9703402029	
236	Controller PCB Assy	9703695025	9703695018		943	Wire Clamp	0600231019	0600231019	
240	Remote Control Unit	9703173066	9703173059		967	Bonnet-B	313045417959	313045417959	
273	Rear Panel Assy	9364642000	9364642000		982-1	Cord Clamp	9356857009	9356857009	
287	Cap (Power)	9352173011	9352173011		982-2	Cord Clamp-B	9356858006	9356858006	
320-1	Wire Clamp Metal	313483219905	313483219905		995	Beam	9364647005	9364647005	
324	Top Plate	9364634005	9364634005		996	Drain Pan (S) Assy	9364893013	9364893013	

**[ INDOOR UNIT ]**  
**CONTROLLER PCB ASSEMBLY (Ref. No.236)**

When you order parts, please make a photocopy of this page and fill the number of the parts in the "Order" column.

Ref. No.	Description	Part No.	Ord. Q'ty	Ref. No.	Description	Part No.	Ord. Q'ty
IC1	IC $\mu$ PD78014HCW-030	9703726019		R63	Res. 1/10W 15.4k $\Omega$ $\pm$ 1%	0200279565	
IC2	IC NJM7812FA	0100462104		R64	Res. 1/10W 28.0k $\Omega$ $\pm$ 1%	0201114445	
IC3	IC NJM7805FA	0100462081		C5	Cap. Elec. 450V 100 $\mu$ F	0300256060	
IC5,6	IC PA2003GRE2	0100028041		C6	Cap. Plastic 4700pF	0300269091	
IC7	IC BR93LC46RF-E2	0100295016		C7	Cap. Plastic 50V 0.047 $\mu$ F	0300169339	
IC8	IC PST600CMTR	0101461120		C8	Cap. Elec. 25V 100 $\mu$ F	0301197560	
IC10	IC HI2002	9701384020		C9	Cap. Elec. 25V 1000 $\mu$ F	0301196495	
IC11	IC BA10358FE2	0101846071		C10,11,33,36	Cap. Elec. 25V 10 $\mu$ F	0301192312	
Q1	Xstr 2SC4236	0000164047		C12	Cap. Elec. 25V 1000 $\mu$ F	0301158264	
Q2	Xstr 2SC1815	0000002011		C13,15,34,37, 39,44,45	Cap. Ceramic 50V 0.1 $\mu$ F	0300311752	
Q3,4	Xstr DTC124EKA	0000936033		C14	Cap. Elec. 25V 100 $\mu$ F	0301192350	
Q5,6	Xstr 2SC2712	0000781053		C16,17,19-31, 38,40,46,49, CJ1	Cap. Ceramic 50V 0.01 $\mu$ F	0300311738	
D1	Diode D3SB60	0000689045		C32,35,50-53	Cap. Ceramic 50V 1000pF	0300308509	
D2,4,7	Diode D1FL20U	0000746519		C54	Cap. Ceramic 0.01 $\mu$ F	0300209127	
D3	Diode MTZJ5.1B	0000852166		VA3	Varistor TNR12G471K	0000038010	
D5	Diode 1SR139-600	0000353120		K2,4	Relay JQ1-12V	9701316014	
D6	Diode D2FL20U	0000906500		CR1	Network RPEL-121204 -C	9701125012	
D10	Diode DA226U	0000625036		SW1	Switch, Slide DSS803	9701392018	
D12	Diode DAN202K	0000684019		SW2	Switch, Rotary DRS4016-5	9701694013	
R1	Res. Cement 5W 3.3 $\Omega$ $\pm$ 10%	0200153148		T1	Switching Transformer ETS28AS118AH	9702727017	
R2	Res. Metal 2W 1.5 $\Omega$ $\pm$ 5%	0201107119		X1	Ceramic Resonator EF0EC8384T4	9701261017	
R3	Res. 1/10W 100 $\Omega$ $\pm$ 5%	0200212500		L2-4	EMI Filter EXCEMT103DT	0400406396	
R4	Res. Carbon 220k $\Omega$ $\pm$ 5%	0200111353		CJ2	Res. 0 $\Omega$	0200212012	
R5	Res. Metal 2W 47k $\Omega$ $\pm$ 5%	0201107652		JM9	Res. 0 $\Omega$	0200230016	
R6	Res. 1/2W 100 $\Omega$ $\pm$ 5%	0200731506		CN1	Plug, PCB 5-1123724-3	0501321635	
R7	Res. 1/4W 330 $\Omega$ $\pm$ 5%	0200708621		CN4	Plug, PCB 2-1123724-2	0501321529	
R8,10,14-17, 21-24,29-32, 37,39,48,50, 52,55,59,60, 61,66,68	Res. 1/10W 10k $\Omega$ $\pm$ 5%	0200213019		CN5	Plug, PCB 1-1123724-3	0501321451	
R9,47,65	Res. 1/10W 390 $\Omega$ $\pm$ 5%	0200212647		CN6	Plug, PCB 3-1123724-2	0501321536	
R18-20,25-28, 33-36,38,42, 44,46,49,51, 58,67	Res. 1/10W 1k $\Omega$ $\pm$ 5%	0200212746		CN7	Plug, PCB B2B-XAKK-1-A	0501045227	
R40,41,62	Res. 1/10W 4.7k $\Omega$ $\pm$ 5%	0200212906		CN8	Plug, PCB B2B-XASK-1-A	0501045012	
R43	Res. 1/10W 10k $\Omega$ $\pm$ 1%	0200279497		CN9	Plug, PCB B5P-SHF-1AA	0500006069	
R45	Res. 1/10W 49.9k $\Omega$ $\pm$ 1%	0200279824		CN14	Plug, PCB B4B-XH-AM	0500005314	
				CN15	Plug, PCB B3B-XARK-1-A	0501045319	
				CN17	Plug, PCB B3B-XAKK-1-A	0501045357	

**FILTER PCB ASSEMBLY (Ref. No.875)**

Ref. No.	Description	Part No.	Ord. Q'ty	Ref. No.	Description	Part No.	Ord. Q'ty
F101	Fuse 2183.15	0600285210		C101,102	Cap. Plastic 0.22 $\mu$ F	0300304099	
FH1,2	Fuse Holder PFC5000-0502	0500158072		C105,106	Cap. Plastic 0.022 $\mu$ F	0301052098	
VA101,102	Varistor TNR12G471K	0000038010		LF101	EMI Filter ELF17N015A	0400197119	
SA101	Arrester DSA-362MA-05	0600168032		E101	Wire w/Terminal GRN L=100	9702313012	
TM101,102	Plug Contact 86028	0500536016		W103,104	Wire w/Terminal #18 3P	9703679018	



[ OUTDOOR UNIT ]  
CONTROLLER PCB ASSEMBLY (Ref. No.236)

When you order parts, please make a photocopy of this page and fill the number of the parts in the "Order" column.





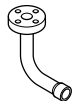
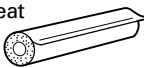

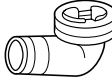



Ref. No.	Description	Part No.	Ord. Q'ty	Ref. No.	Description	Part No.	Ord. Q'ty
IC1	IC $\mu$ PD780024ACW-020	9703727016		C1,2	Cap. Plastic 0.22 $\mu$ F	0300304099	
IC2	IC NJM7805FA	0100462081		C3,4	Cap. Plastic 0.022 $\mu$ F	0301052098	
IC3,4	Xstr Array $\mu$ PA2003GR	0100028041		C5	Cap. Elec. 25V 1000 $\mu$ F	0301196495	
IC6	IC PST600CMT	0101461120		C6	Cap. Elec. 50V 1000 $\mu$ F	0301196822	
IC7	ICHU2001	9701651016		C7,14,38-41, 51-54,CJ35, CJ48	Cap. Ceramic 50V 0.01 $\mu$ F	0300311738	
IC9	ICNJM7824FA	0100462098		C8,29-31	Cap. Elec. 25V 10 $\mu$ F	0301192312	
IC10	ICNM/FM93C46M8-X	0101622026		C10	Cap. Elec. 50V 100 $\mu$ F	0301192589	
PC1	Photocoupler TLP621(D4)-GB	0000117074		C12,13,17-19, 36,42-46	Cap. Ceramic 50V 0.1 $\mu$ F	0300311752	
Q3,8,14	Xstr DTC124EKA	0000936033		C15,16,23-25	Cap. Ceramic 50V 1000pF $\pm$ 10%	0300308509	
Q5,6	Xstr 2SC2712	0000781053		C27	Cap. Elec. 450V 100 $\mu$ F	0300256060	
Q9	Xstr 2SC4236	0000164016		C28	Cap. Plastic 25V 4700pF	0300269091	
Q10	Xstr 2SC1740S	0000699235		C35	Cap. Plastic 50V 0.047 $\mu$ F	0300169339	
D1,23	Diode D1F60	0000208024		C37	Cap. Elec. 25V 100 $\mu$ F	0301197560	
D2,3	Diode D2FL20U	0000906500		C47	Cap. Elec. 25V 100 $\mu$ F	0301192350	
D6,7	Diode DA226U	0000625036		C49	Cap. Ceramic 0.01 $\mu$ F	0300209127	
D11	Diode DAN202K	0000684019		K1-5	Relay JQ1-12V	9701316014	
D14	Diode D3SB60	0000689045		CR1,2,4	CR Absorber RPEL-121204-C	9701125012	
D18	Diode MTZJ5.1B	0000852166		HT1	Heat Sink PUE56-30	9703347016	
D19	Diode 1SR139-600	0000353120		T1	Switching Tranformer ETS 29AA175AC	9703059018	
D20,21	Diode D1FL20U	0000746519		VA1-3	Varistor TNR12G471K	0000038010	
LED1-6	Diode SLR-325VC	0000813259		SA1	Arrester RA-362M-V7-F	0600280154	
R1,3-5	Res. 1/10W 4.7k $\Omega$ $\pm$ 5%	0200212906		LF1	EMI Filter ELF15N005A	0400165040	
R2	Res. 1/4W 10k $\Omega$ $\pm$ 5%	0200231013		F1	Fuse BET 6.3A-250V	0600222574	
R7,8,11-13, 23-26,30-36, 54,55,77-80	Res. 1/10W 1k $\Omega$ $\pm$ 5%	0200212746		SW1	Slide Switch DSS804	9701393015	
R9,10,27,37- 40,43-45,47, 49-52,56-58,76	Res. 1/10W 10k $\Omega$ $\pm$ 5%	0200213019		E	Wire w/Terminal L=100 GRN	9702313012	
R17	Res. 1/10W 38.3k $\Omega$ $\pm$ 1%	0201114575		W1	Wire w/Terminal L=330 RED	9702929015	
R18	Res. 1/10W 14k $\Omega$ $\pm$ 1%	0201114193		X1	Ceramic Resonator EFOEC8384T4	9701261017	
R19	Res. 1/10W 6.65k $\Omega$ $\pm$ 1%	0201113806		FH1,2	Fuse Holder PFC5000-0502	0500158072	
CJ26-28,37	Res. 1/10W 0 $\Omega$	0200212012		CN3	Plug, PCB B3P5-VH-B	0500011735	
R46	Res. Wire Wound 5W 3.3 $\Omega$ $\pm$ 5%	0200244372		CN4	Plug, PCB 179844-1	0501121013	
R59-62	Res. 1/4W 10 $\Omega$ $\pm$ 5%	0200230269		CN7	Plug, PCB B3P5-VH-B-C	0500011810	
R67	Res. Metal Oxide 2W 1.5k $\Omega$ $\pm$ 5%	0201107119		CN9	Plug, PCB B6B-XAKK-1-A	0501045425	
R68	Res. Metal Film 2W 330k $\Omega$ $\pm$ 5%	9703493010		CN10	Plug, PCB B3B-XASK-1-A	0501045029	
R69	Res. 1/10W 100k $\Omega$ $\pm$ 5%	0200212500		CN11	Plug, PCB B6B-XASK-1-A	0501045050	
R70	Res. 1/4W 330 $\Omega$ $\pm$ 5%	0200230627		CN13	Plug, PCB B2P-VH-B	0500011124	
R71	Res. 1/2W 100 $\Omega$ $\pm$ 5%	0200731506		CN14	Plug, PCB B5P-SHF-1AA	0500006069	
R81	Res. Metal Oxide 2W 62k $\Omega$ $\pm$ 5%	0201107997		CN16	Plug, PCB B3P5-VH-B-R	0500011803	
R82	Res. Metal Oxide 1W 56k $\Omega$ $\pm$ 5%	0201106662		CN18	Plug, PCB B3B-XARK-1-A	0501045319	

# STANDARD ACCESSORIES

## OUTDOOR UNIT ACCESSORIES

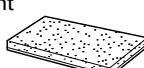
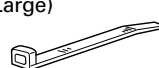
Name and Shape	Q'ty	Application	RO-90EPA	RO-90TPA
Flange joint assembly 	1	For connecting the piping	9363035001	9363035001
Coupler heat insulation 	1	For outdoor side pipe joint	9363828009	9363828009
Gasket 	1	Installation between flange joint assembly and valve B	9363272000	9363272000
Bolt 	2	For fixing the flange joint assembly	0700145100	0700145100
Drain pipe 	3	For outdoor unit drain piping work (Reverse cycle model only)	—	9301102000

## INDOOR UNIT ACCESSORIES

Name and Shape	Q'ty	Application	RD-90EA	RD-90TA
Remote control unit 	1	Use for air conditioner operation	9703173066 (EZ-0001WSE-R)	9703173059 (EZ-0001HSE-R)
Flange joint 	1	For connecting the piping	9365352007	9365352007
Gasket 	1	Installation between flange joint and indoor unit	9363272000	9363272000
Special nut A (Large flange) 	4	For suspending the indoor unit from ceiling	313005446653	313005446653
Special nut B (Small flange) 	4		313005446759	313005446759
Washer 	8		9364938004	9364938004
Coupler heat insulation 	1	For indoor side pipe joint (small)	9350716029	9350716029
Flange joint insulation 	1	For indoor side pipe joint (large)	9364937007	9364937007
Binder (Large) 	1	For fixing the connection pipe (Large and small)	9366156000	9366156000
Binder (Small) 	1	For fixing the remote control unit cord	313361275805	313361275805
Remote control unit cord clamp 	10	For installing the remote control unit cord	313714181904	313714181904
Screw 	10	For installing the remote control unit cord clamp	301141153027	301141153027
	2	For installing the remote control unit	301141134166	301141134166



MANUFACTURER :

**Fuji Denki Sosetsu Co., Ltd.**

Tokyo, Japan

0011J1770

November 2000 Printed in Japan



**Большая библиотека технической документации**

<https://splitsystema48.ru/instrukcii-po-ekspluatácii-kondicionerov.html>

**каталоги, инструкции, сервисные мануалы, схемы.**